



Trimline 100 Panoramic/Corner Left/Corner Right DB 1156/1157/1158
Trimline 120 Panoramic/Corner Left/Corner Right DB 1145/1146/1147
Trimline 140 Panoramic/Corner Left/Corner Right DB 1140/1141/1142

INSTALLATION INSTRUCTION

For other languages, download the manual, open it in Acrobat Reader and choose the desired language with the buttons on the bottom side of this page.

CONTENTS

1	INSTALLATION INSTRUCTIONS	3
2	PLACING THE APPLIANCE	3
2.1	Preparation and installation	3
2.2	Connection to the gas supply pipes	4
3	REMOVING AND INSTALLING THE GLASS PANEL	5
3.1	Removing the glass panel	5
3.2	Installation of the front window	5
3.3	AR glass (Optional)	6
4	INSTALLATION OF THE CERAMIC WOOD SET AND DISPERSION MEDIUM	7
5	INSTALLATION HIGH GLOSS BLACK GLASS (OPTIONAL)	9
6	TECHNICAL DETAILS MAXITROL GV60	11
7	INSTRUCTIONS FOR MAXITROL GV60	13
8	GAS-TECHNICAL SPECIFICATIONS.....	14
	- Trimline 100 Panoramic/Corner (1156/1157/1158).....	14
	- Trimline 120 Panoramic/Corner (1145/1146/1147).....	16
	- Trimline 140 Panoramic/Corner (1140/1141/1142).....	18
9	CONCENTRIC PATHWAYS	20
	- Trimline 100 Panoramic/Corner (1156/1157/1158).....	20
	- Trimline 120 Panoramic/Corner (1145/1146/1147).....	22
	- Trimline 140 Panoramic/Corner (1140/1141/1142).....	24
10	CONCENTRIC FLUE SYSTEM	26
10.1	Components of the concentric flue system	26
10.2	Construction of concentric flue system	26
10.3	Installation instructions regarding existing flues	26
10.4	Parts	27
10.5	Installation	27
11	PASS-THROUGH POSITIONS AND FUNCTION CORRECTLY	28
12	CLEANING AND MAINTENANCE	29
13	QUICK REFERENCE GUIDE FOR FAULTSSEARCH FOR ENCLOSED GAS FIRES USING MERTIK GV60 GASCONTROL	30
Appendix 2	Built-in examples	34
Appendix 3	Construction diagram double-wall concentric	35
Appendix 4	Preparation and installation	36
Appendix 5	Preparing gas cassette GV60 for installation.....	37
Appendix 6	Exploded view and spare parts	39
Appendix 7	Type plate	41
Appendix 8	Declaration of conformity.....	43
Appendix 9	Product data sheet	44
Appendix 10	Energy label.....	51

thermoCet International B.V.
Laagerfseweg 27
3931 PC Woudenberg
The Netherlands
www.trimlinefires.com



Modifications and printerrors are reserved.

thermoCet International BV is not responsible for any
(consequential) damage due to incorrect installation.

V110526



1 INSTALLATION INSTRUCTIONS

NOTE

The installation should be performed only by an authorized gasfitter.

- 1 The appliance must be installed, connected, inspected and serviced as a closed appliance by a qualified fitter, according to local standards and regulations.
- 2 The flue tube system and the outlets in the outer wall or roof face must also meet the requirements outlined in the applicable local standards and regulations.
- 3 The temperature of the walls near the side and back of the appliance may not exceed the ambient temperature by 60 K or more. For example, ambient temperature 20 °C, maximum increase of 60 K gives a maximum temperature of 80 °C
- 4 The appliance has been approved in combination with the concentric flue system THC/Holetterm in accordance with European CE standards for gas appliances, and may therefore only be applied with this system.
- 5 The appliance needs to be inspected by the fitter for local gas distribution (gas type and gas pressure) as indicated on the identification plate.
- 6 The instructions are only applicable if the relevant country code is stated on the appliance.
- 7 There will be air in the gas pipes when the appliance is first used. The gas supply pipes therefore need to be vented first.

- 8 Ignite the appliance according to the user manual and check the flame is burning evenly. After the appliance has been used for the first time, any deposits resulting from curing must be removed from the glass panel using a glass cleaner made specifically for fireplaces.

Distance from flammable materials in the vicinity of the appliance

Do not place flammable materials within 500mm of the part of the appliance that radiates heat.

Distance to non-flammable materials

The appliance needs to be placed a minimum distance of 25mm from the wall unless stated otherwise in these instructions.

WARNING

- 1 Gas fires become hot when in use. After installation of the appliance, the glass panel surface is considered to be an active zone. The glass panel surface can become very hot.
- 2 Therefore, you should take care by, for example, keeping children and those requiring help away from the immediate vicinity of burning fires. Gas fires must not be placed on or against flammable materials.

2 PLACING THE APPLIANCE

NOTE

- 1 Before installing the appliance, please read Chapter 3 *Removing and installing the glass panel*, 9 *Concentric pathways*, 10 *Concentric flue system* and **APPENDIX 2**.
- 2 Do not start the installation until you have read and understood the installation instructions.

2.1 Preparation and installation

- 1 Check the packaging for damage. Remove the packaging and check the contents are intact and complete. Report damage and defects to the supplier immediately.
- 2 The packaging contains the following components:

- Unit	- 2 x AA battery
- Remote control	- Suction cup(s)
- Ceramic wood set	- Adjustable feet
- Bag of glow wool	- Built-in cassette
- Bag of grit	- 2 Convection grilles
- Bag of small chips	- Installation instruction
- Bag of large chips	- User manual
- Restrictor(s)	- Lifting brackets
- 4 x AA battery	APPENDIX 4 1
- 3 Place the appliance on a stable surface. Remove the glass panel (see Chapter 3 *Removing and installing the glass panel*) so you can take out the packaged parts. Check it for damage and defects.

- 4 Put the appliance in place using the adjustable feet (supplied) and the wall mounting. The adjustable feet can be used for fine adjustment of the appliance; an optional leg extension set is also available. **APPENDIX 4 Image 5**
- 5 The gas valve must be installed in the gas control box (see Paragraph 2.2 *Connection to the gas supply pipes*).
- 6 The distance between the gas valve and the appliance is determined by the cable length (maximum 1200mm).
- 7 The flue path determines whether a restrictor and/or baffle plate must be fitted (refer to Chapter 9 *Concentric pathways* and **APPENDIX 4 Preparation and installation**).
- 8 The baffle plate is fitted with a screw in the middle on the front side. The baffle plate can be taken out by removing the screw and sliding the baffle plate backwards. If applicable, the restrictor can be placed with two screws.
- 9 Connect the appliance to the concentric flue system.
- 10 Position the supplied convection grilles at least 500 mm below the ceiling. If the space between the grille and the top of the ceiling in the chimney is very high, it is recommended that a false ceiling made of refractory material be installed in the chimney. **APPENDIX 2**

2.2 Connection to the gas supply pipes

- 1 Remove the protective bracket under the appliance complete with gas valve (remove the tie straps) and secure it in the gas control box with the wing nut, which can be found inside. **APPENDIX 5**
- 2 Take into account which power supply is provided: batteries or 230V adapter.
- 3 You can determine where the gas supply pipes will be placed, dependent on the layout. Ensure control equipment is not twisted during installation and there is no excessive tension. Accessibility of various connection points in relation to components needs to be maintained. After installation, check the connections are gas-tight. Use a 3/8" gas tap with a connector. Also ensure the gas supply pipe is free from dirt or sand. To prevent damage to the gas control equipment, the gas connection must be isolated from the electrical power.
- 4 Ignite the appliance for the first time without a glass panel. Check all the gas connections for leaks again. You can then switch the appliance off and put the ceramic wood set in place (see Chapter 4 *Installation of the ceramic wood set*).

NOTE

- 1 If the appliance does not work properly and/or the flames do not look good, repeat the previous steps again while checking and correcting if necessary.
- 2 The glass will now need to be cleaned again (see chapter 12 *Cleaning and maintenance*).

3 REMOVING AND INSTALLING THE GLASS PANEL

3.1 Removing the glass panel

- 1 Remove the decorative frame on the underside of the glass panel.
- 2 Loosen the screws retaining the lower and upper glass holders. **APPENDIX 4 2**
- 3 By placing the supplied rubber suction cup(s) in the centre of the glass panel, the glass panel can easily be removed from the appliance by first carefully moving it upwards and then pulling the bottom of the panel very carefully and slowly towards you; the glass panel should then be placed in a safe place where it cannot break or get damaged **APPENDIX 4 3**. If the dismantled glass panel is damaged (scratches and/or damaged edges) do not use the glass panel; notify the supplier.
- 6 Place the front window and make sure it lines up with the side window(s). **4**
- 7 Securely clamp the front window by tightening the glass holder screws **5** or by installing the spring-loaded glass holder*.
- 8 Loosen the side window(s) by unscrewing the glass holder screws (do not remove the glass holder) or by removing the spring-loaded glass holder. **1**
- 9 Carefully slide the side window(s) forward using the suction cup provided **6**. Check that the side windows butt neatly against the front window.
- 10 Hold the side window against the front window and now clamp the side window securely by tightening the glass holder screws or mounting the spring-loaded glass holder*.
- 11 Replace the decorative frames.
- 12 Check again that the fire ignites properly.

3.2 Installation of the front window

NOTICE

Take care when installing the front window to avoid breakage! The side window is held against the front window by spring pressure. When the front window is removed, the side window can inch forward under the influence of this spring pressure.

To avoid this, proceed as follows to replace the front window:

- 1 The side window does not need to be removed, but it does need to be pushed back.
- 2 Loosen the screws retaining the side window glass holders **1** (do not remove the glass holder), or remove the spring-loaded glass holder*.
- 3 Place the suction cup on the side window and slide it backwards against the spring pressure **2**, until it lies behind the plane of contact with the front window. **3**
- 4 Clamp the side window(s) by tightening the glass holder screws or by installing the spring-loaded glass holder*.
- 5 Make sure the seals are complete, intact and clean.

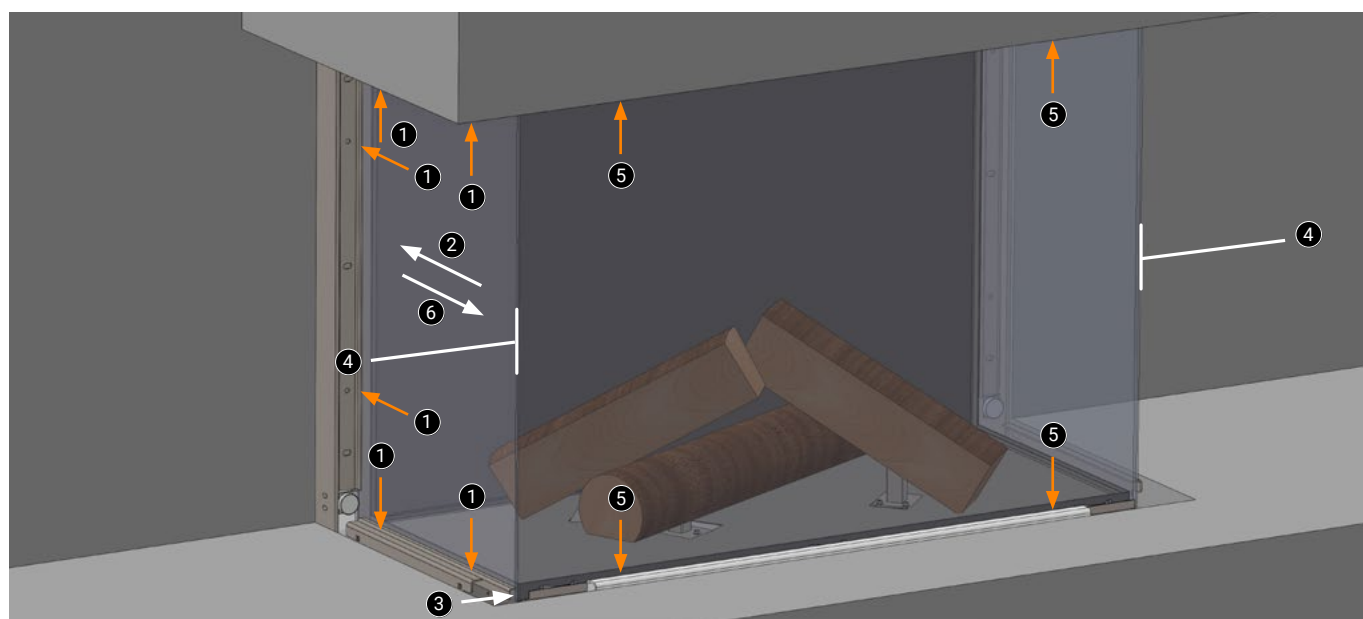
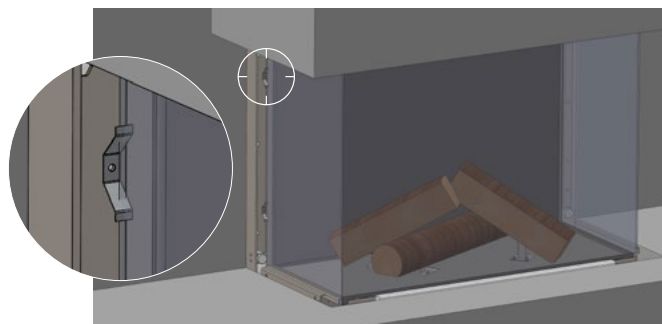

* Depending on the version.

3.3 AR glass (Optional)

AR glass is a non-reflecting glass. This glass has an AR coating on both sides of the glass. The anti-reflection layer reduces the reflection to a minimal gloss.

NOTE

- 1 The AR glass with coating is more sensitive to damage than normal glass.
- 2 Always wear soft cotton gloves when removing and installing AR glass.
- 3 The rubber suction cup(s) must be clean.
- 4 If the dismantled glass panel is damaged (scratches and/or damaged edges) do not use the glass pane; notify the supplier.
- 5 Use the thermoCet cleaner set to clean the AR glass. Other cleaning agents can damage the AR glass coating.
- 6 Do not use hard (abrasive) sponges, steel wool, abrasives and/or cleaning agents containing ammonia, (citric) acid or ceramic hob cleaner.
- 7 Do not leave any residue, such as fingerprints, behind. These will burn in and cannot be removed.

IMPORTANT

After lighting for the first time, a haze may form on the inside of the glass panel. When the appliance has cooled down after the first use, the glass must be cleaned immediately. The glass must be cleaned again after the appliance has been in use for a month. After this, the amount of cleaning can be determined depending on the frequency of use of the appliance. Bear in mind that the glass can become dull if it is not cleaned in good time. Cleaning then becomes more difficult

4 INSTALLATION OF THE CERAMIC WOOD SET AND DISPERSION MEDIUM

NOTE

- 1 If a choice has been made to install the optional rear wall, this must be installed before positioning the logs. See Chapter 5 *Installation high gloss black glass (Optional)*.
- 2 In certain exhaust routes, the baffle plate is not replaced, see Chapter 7 *Concentric Pathways*.

- 1 Spread the grit evenly over the burner so that it is just covered **1**. Place the large chips on the grille around the burner **2**.
- 2 Then put the logs in place in the correct order **3**. Be careful when handling the logs. Placing the logs in the wrong place can have a negative affect on the flames and/or prevent the burner from working properly (soot formation).

- 3 If desired, some small chips can be placed in the open spaces between the logs on the burner.
- 4 Some glowing material can be placed here and there for decoration.
- 5 Before reinserting the glass panels, check whether or not a restrictor needs to be installed.
- 6 See chapter 7 *Concentric Pathways*. Remove the baffle plate by unscrewing it at the front of the plate and then taking it out to the rear.
- 7 Fit the restrictor with the two screws supplied if this has been prescribed for your situation **APPENDIX 4 6**. Refit the baffle plate in the reverse order.
- 8 Ignite the appliance, check the pilot flame and burners light easily and that the flames flow evenly along the logs. If this is not the case, check or adjust the position of the logs.



Trimline 100 Panoramic/Corner



Trimline 120 Panoramic/Corner

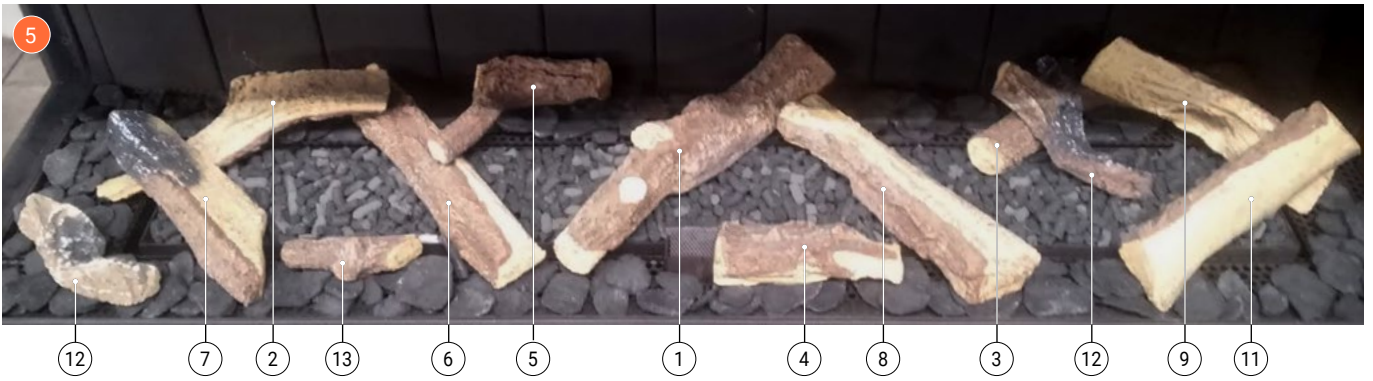

Trimline 140 Panoramic/Corner

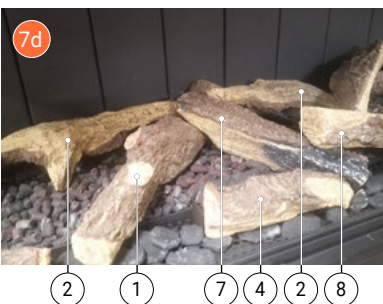
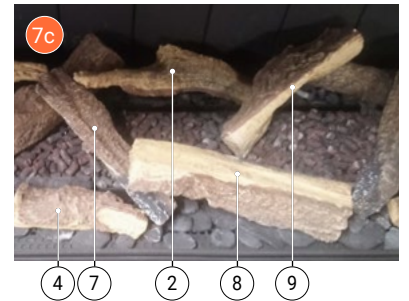
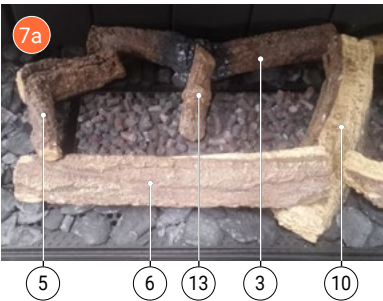
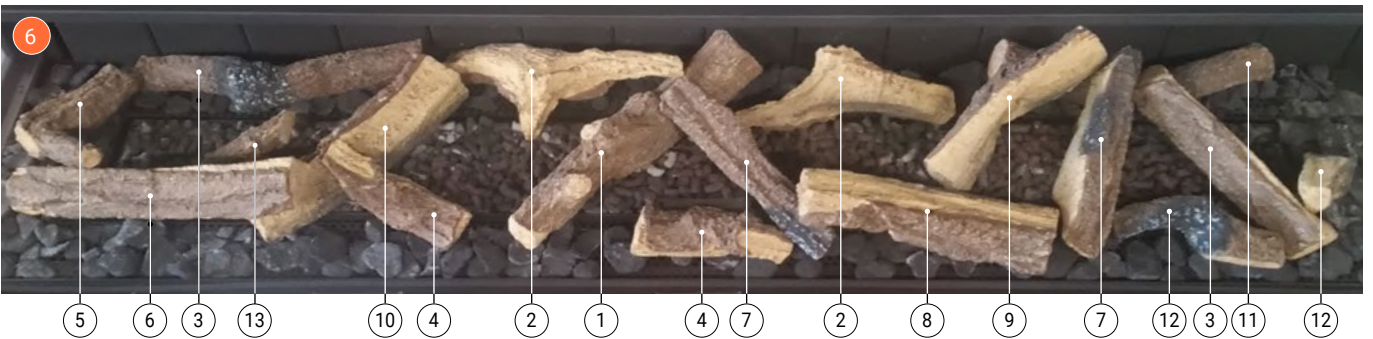

V110526



5 INSTALLATION HIGH GLOSS BLACK GLASS (OPTIONAL)

- 1 Remove the decorative frame on the underside of the glass panel.
- 2 Loosen the screws retaining the lower and upper glass holders. **1 2**
- 3 Place the suction cup centrally on the glass panel. Slide the glass upwards and then tilt the bottom edge towards you to remove the glass panel **3**. Put the glass panel in a place where it will not get damaged.
- 4 Take out the grille **4**. Lift the grille up and remove it by tilting it **5**. You can see the slats in the rebate. **6**
- 5 Each slat can be taken out by hand: push the slat upwards, pull it towards you with a suitable tool and then lower it. **7 8 9 10 11**
- 6 When all the slats have been removed, you can see a flat rear wall. **12**
- 7 Open the packaging protecting the black glass. The package contains the following parts:
 - Slats **13**
 - Black glass **14**
 - Two mounting brackets and screws **15**
- 8 Place the two slats against the rear wall. The pre-drilled holes are located at the top. Use the screws to loosely fit the brackets. The brackets hold the glass panel in position. If the holes are not visible, the baffle plate must be removed first.

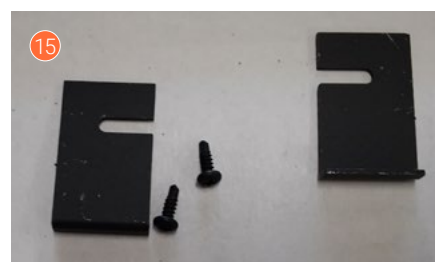
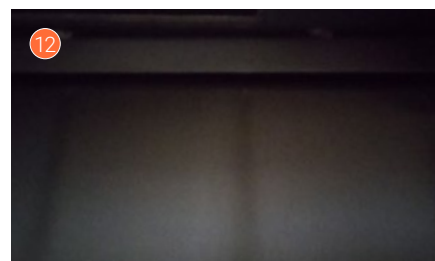
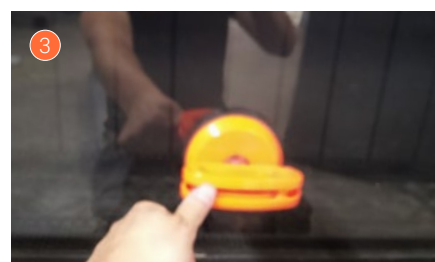
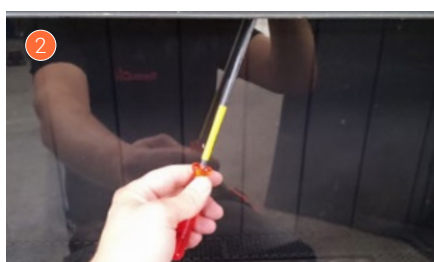
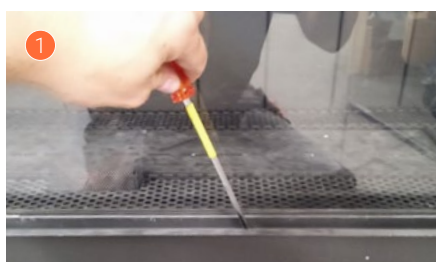

- 9 Place the suction cup centrally on the glass panel. **16**
- 10 Push the black glass panel into the rebate at the top **17**.
Now allow the glass panel to gently slide down into the bottom rebate. **18**

CAUTION

The glass panel is not retained in the rebate at the top and may tip.

- 11 Tighten the screws in the brackets to secure the black glass panel in position. **19 20**
- 12 Reposition the grille. **21**
- 13 Assemble the side using the same procedure as for the rear.

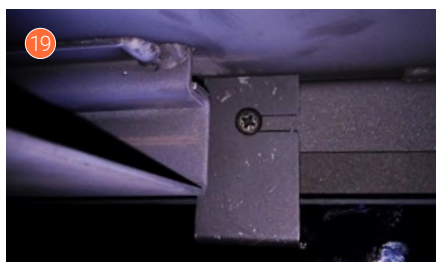

6 TECHNICAL DETAILS MAXITROL GV60

Gas valve type	Maxitrol GV60	
Automatic ignition control type	B6R-R8P (Wifi Ready)	
Ignition	Remote control operation and piezo ignition	
Gas connection	<ul style="list-style-type: none"> ❶ Pilot flame connection ❷ Thermocouple connection ❸ Gas inlet 3/8" external ❹ Gas outlet back burner ❺ Gas outlet front burner 	<ul style="list-style-type: none"> ❻ Multi cable ❼ Piezo connection ❽ Connector double burner ❾ Receiver
Appliance category	C11-C31-C91	
Pilot flame	SIT 3 flames	
Security	Thermocouple principle	

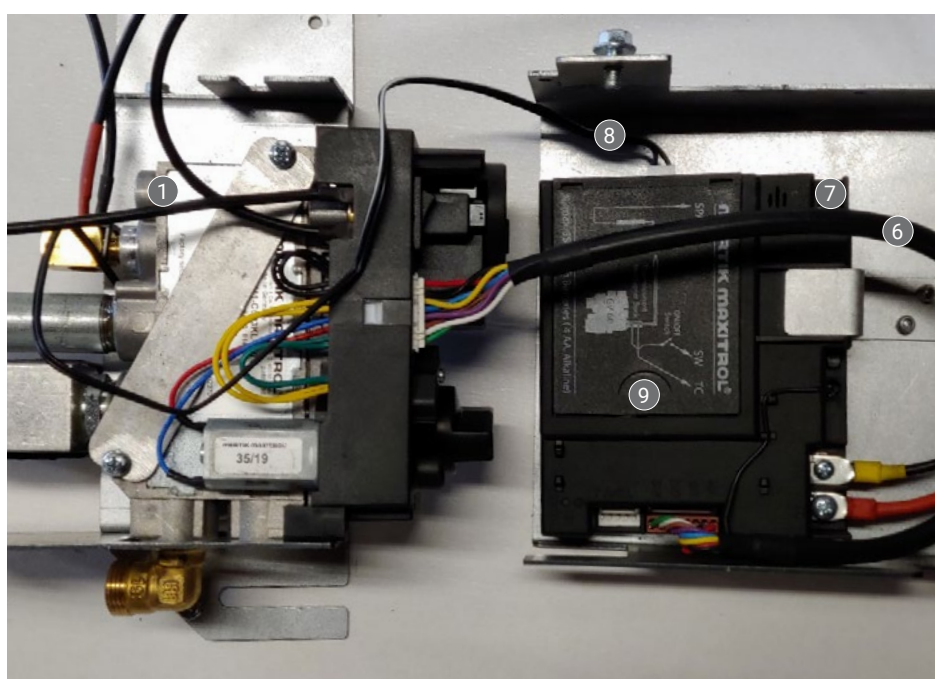
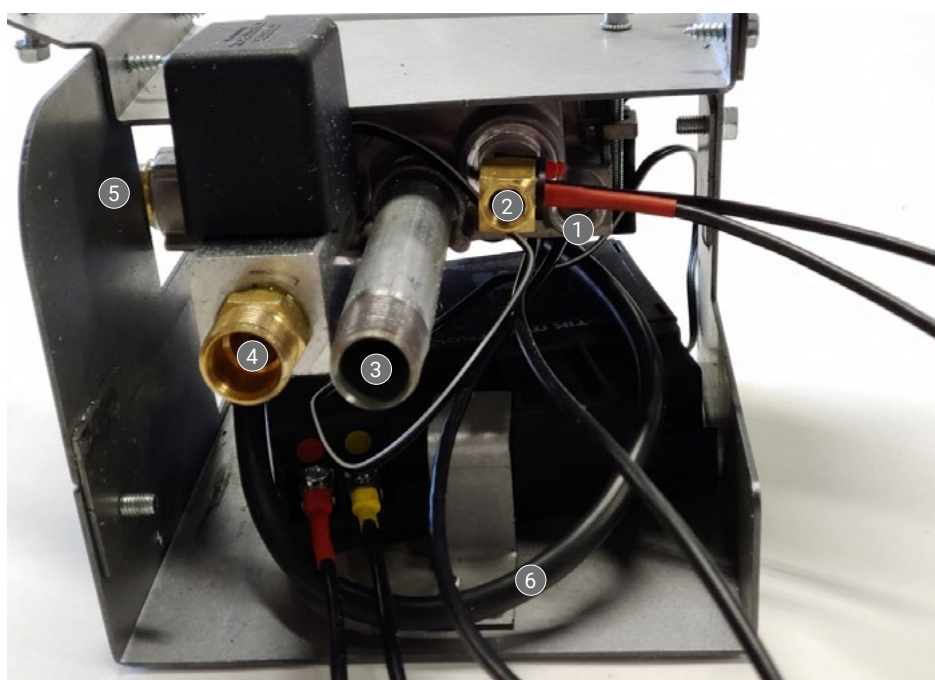

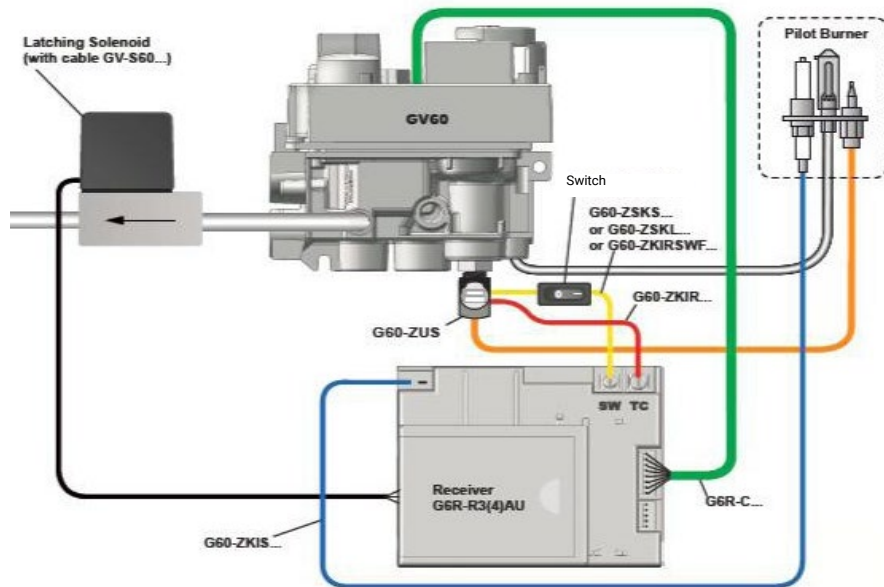
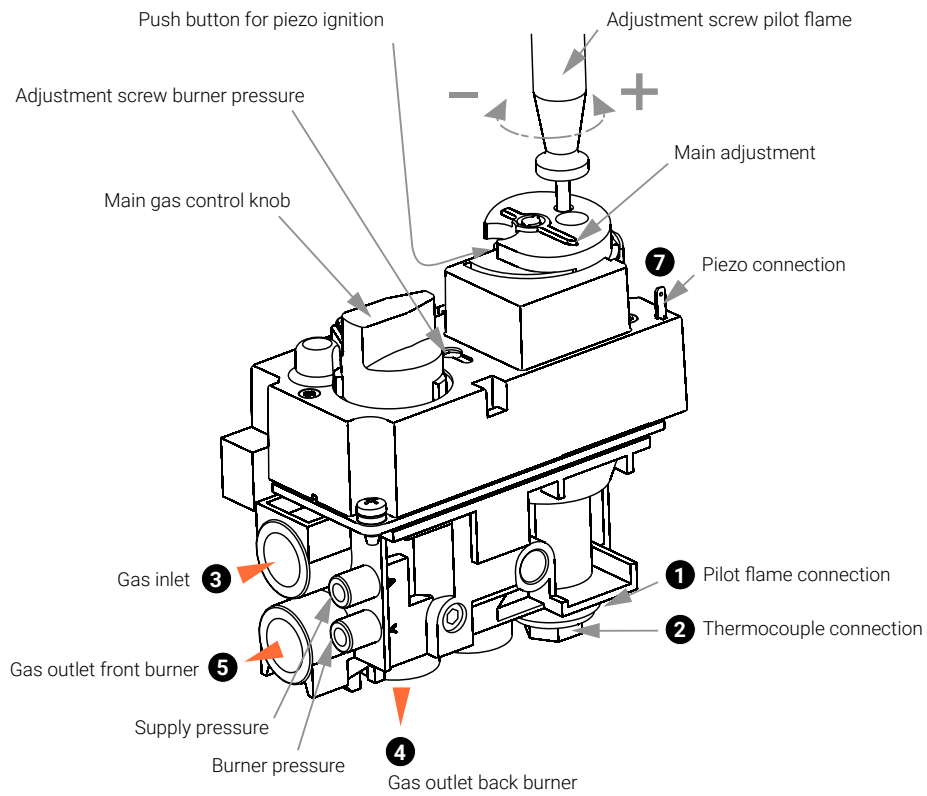

Schematic diagram.

⚠ WARNING

Sealed parts must not be adjusted.

7 INSTRUCTIONS FOR MAXITROL GV60

WARNING

- 1 Ensure the fuel supplied to the appliance is clean and free from particles and moisture.
- 2 The appliance must not be turned on if the glass pane(s) is not present and/or is broken.

Before a gas supply pipe (new or existing) is connected to the main gas pipe at the gas meter and to the gas valve of the appliance, clean and dry compressed air needs to have been blown through it. Copper and aluminium pilot flame pipes that have been cut must be deburred and blown clean before they are connected.

Heat, moisture and dust are a threat to all electronic components

Protect the electronic gas control until all construction, plastering and paintwork has been completed. If you cannot avoid this work, then protect the control against dirt and moisture penetration by covering it with plastic film for instance.

WARNING

- 3 Electronic components become permanently faulty when they are exposed to temperatures higher than 60°C. Normal AA batteries will crack open at temperatures >54°C and the battery contents will damage the electronic switches below. Batteries have the longest life span at <25°C.
- 4 Only install the gas valve and receiver as pre-installed at the factory.
- 5 Remember that components may have to be replaced or that repairs may have to be performed at a later date. This may prove to be more difficult if the control is installed in a different way to how we have described in instructions

Only insert the batteries after the receiver, gas valve and pilot flame have been wired.

Premature connection to the power source can damage the electronics.

NOTE

- 1 Batteries must not be fitted in the receiver when using the power adapter.

Ensure the ignition cable is not near the antenna wire and that they do not cross each other.

The high voltage released during ignition may damage the sensitive receiver circuit of the antenna. This could mean the appliance becomes less responsive or totally unresponsive to commands from the handset.

NOTE

- 2 Do not tighten the contact breaker and the thermocouple connection too tightly on the gas valve.
- 3 It is sufficient to tighten by hand and add a half a turn with an open-end spanner. Tightening too much will break the connection to the magnetic coil below and/or the insulation around the aluminium contact pin in the contact breaker. This may cause the magnetic coil to not open the gas supply to the pilot flame and prevent the appliance from functioning.

Prevent leakage of ignition spark to parts of the installation other than the ignition rod on the pilot flame. Ensure the ignition cable is not in contact with the body or other metal parts. If a cable extension is used, ensure the connections have additional silicone insulation.

The receiver and the control units on the gas valve should be switched on to ensure automatic start-up via the remote control. The oval disc on the gas valve should be turned to the **ON** position. The **I/O** switch should be set to **I**. The ignition cable should be connected to the **SPARK** connection point on the receiver.

The system's thermostat sensor is located inside the remote control. The remote control operates best at a distance of 2 or 3 metres away from the appliance. Although communication occurs via shortwave radio signals, it is recommended that you place the remote control in the line of sight of the gas appliance, in a place where the user wishes to experience a pleasant temperature. Do not place the manual transmitter in direct sunlight or other warm locations. The thermostat measures the temperature and, accordingly, regulates the flame size of the gas appliance.

NOTE

- 4 Sealed parts must not be adjusted, to do so would void the warranty.
- 5 A waiting time of 5 minutes between each start attempt must be observed.
- 6 Remove batteries not with a metal tool. Removing batteries with a metal object can permanently damage the electronic control.

8 GAS-TECHNICAL SPECIFICATIONS

Type of indication(s)		Trimline 100 Panoramic/Corner (1156-1157-1158)					
Appliance type		C11 C31 C91					
Balanced flue system		Holetherm CC 130 - 200					
Gas type		G25.3	G20		G20	G20=G25	G20/G25
Country		NL	AT/CH/CZ/DK/EE/ ES/ FI/GB/GR/HR/ HU/IE/IT/ LT/LV/N O/PT/RO/SE/SI/ SK /TR		DE/PL/RO	BE/FR	DE
Category		I2EK	I2H		I2E	I2E+	I2ELL
		I2(43,46-45,3 MJ/m ³)					
Primary air per burner		mm	2x(2xØ5mm)		2x(2xØ5mm)		
Symbol							
Pnom	Supply pressure	mbar	25	20	20	20=25	20
Pb-High	Burner pressure - high position	mbar	17,37	13,92	13,92	13,92=17,37	14,1
Pb-Low	Burner pressure - low position	mbar	4,6	3,71	3,71	3,71=4,6	3,6
Injector orifice		Ø mm	2xØ2		2xØ2		
Pilot flame injector		CODE	51		51		
Low position orifice		mm	1,8		1,8		
Qn	Load Hs	kW	11,71	12,49	12,49	12,49=11,71	10,10
Qn	Load Hi	kW	10,55	11,25	11,25	11,3=10,5	9,09
Vmax	Gas consumption	m ³ /h	1,27	1,19	1,19	1,19	1,119
Vpilot	Gas consumption	m ³ /h	0,0280	0,0270	0,0270	0,0270	0,0270
Pnom Hi	Nominal power - high position	kW	8,02	8,66	8,66	8,66	6,66
Pmin Hi	Nominal power - low position	kW	2,33	2,54	2,54	2,54	1,88
NOx classes			5	5	5	5	5
NOx Hs		mg/kWh	77,37	74,87	74,87	74,87	83,08

5 Pa min pressure in Flue system. conditions EN 613						
Tout	Flue gas Temp	C°	332,3		339,7	320,3
Tin	Air In Temp	C°	59,2		58,1	58,1
	CO ₂	%	5		5,4	4,2
ṁ	Mass flow	gr/sec	6,41		6,44	4,95

Rendement (NCV)							
η _{th.nom}	For nominal heat output	%	76	77	77	77	73,24
η _{th.min}	For minimal heat output	%	53,34	54,72	54,72	54,72	50,25
η _s	Seasonal energy efficiency for space heating	%	73,27	74,21	74,21	74,21	70,53

Additional electricity consumption (option)						
el _{max}	Nominal	kWh			0,0072	
el _{min}	Minimal	kWh			0,0003	
el _{sb}	Stand-by	kWh			0,0003	

Energy efficiency ***							
Energy efficiency index		EEL	73	74	74	74	71
Energy label			D	D	D	D	E

Type of heat output/room temperature control	
Indirect heat functionality	No
Single stage heat output, no room temperature control	No
2 or more manually-adjustable stages, no control of the room temperature	No
With mechanical control of room temperature by thermostat	No
With electronic control of room temperature	No
With electronic control of room temperature plus day-time switch	No
With electronic control of room temperature plus week-time switch	Yes

Other control options	
Control of room temperature with presence detection*	Yes
Control of room temperature with open window detection*	Yes
Distance control options*	Yes
Adaptive start control	No
Working time limitation	No
Black bulb sensor	No
Self-learning functionality	No
Control accuracy	No

* in combination with home automation

*** EU directive 2024/1103 2015/1186

V110526

Type of indication(s)			Trimline 100 Panoramic/Corner (1156-1157-1158)		
Appliance type			C11	C31	C91
Balanced flue system			Holetherm CC 130 - 200		
Gas type			G30/G31	G30	G30
Country			BE/CH/CY/CZ/ES/FR/GB/GR/IE/IT/LT/PT/SI/TR	CY/CZ/DK/EE/FI/GR/HR/HU/IT/LT/NL/NO/PL/RO/SE/SI/TR	Adjust when used AT/CH/DE/LU
Category			I3+	I3B/P	I3B/P (50mbar) If burner pressure is 50mbar, adjust burner pressure high and low
Symbol	Primary air per burner	mm	2x(3xØ16mm)		
Pnom	Supply pressure	mbar	(28-30)-37	30	50
Pb-High	Burner pressure - high position	mbar	28,39	28,39	28,39
Pb-low	Burner pressure - low position	mbar	8,67	8,67	8,67
	Injector orifice	Ø mm	2xØ1,15		
	Pilot flame injector	CODE	30		
	Low position orifice	mm	1,3		
Qn	Load Hs	kW	9,68	9,68	9,68
Qn	Load Hi	kW	8,93	8,93	8,93
Vmax	Gas consumption	m³/h	0,277	0,277	0,277
Vmax	Gas consumption	kg/h	0,52	0,52	0,52
Vpilot	Gas consumption	m³/h	0,0075	0,0075	0,0075
Pnom Hi	Nominal power - high position	kW	7,49	7,49	7,49
Pmin Hi	Nominal power - low position	kW	2,75	2,75	2,75
	NOx classes		5	5	5
	NOx Hs	mg/kWh	61,59	61,59	61,59

5 Pa min pressure in Flue system. conditions EN 613			
Tout	Flue gas Temp	C°	289,6
Tin	Air InTemp	C°	78,7
	CO ₂	%	6,9
ṁ	Mass flow	gr/sec	4,93

Rendement (NCV)			
η _{th.nom}	For nominal heat output	%	83,87
η _{th.min}	For minimal heat output	%	72,28
η _s	Seasonal energy efficiency for space heating	%	80,65

Additional electricity consumption (option)			
el _{max}	Nominal	kWh	0,0072
el _{min}	Minimal	kWh	0,0003
el _{sb}	Stand-by	kWh	0,0003

Energy efficiency ***			
Energy efficiency index	EEL	81	81
Energy label		C	C

Type of heat output/room temperature control	
Indirect heat functionality	No
Single stage heat output, no room temperature control	No
2 or more manually-adjustable stages, no control of the room temperature	No
With mechanical control of room temperature by thermostat	No
With electronic control of room temperature	No
With electronic control of room temperature plus day-time switch	No
With electronic control of room temperature plus week-time switch	Yes

Other control options	
Control of room temperature with presence detection*	Yes
Control of room temperature with open window detection*	Yes
Distance control options*	Yes
Adaptive start control	No
Working time limitation	No
Black bulb sensor	No
Self-learning functionality	No
Control accuracy	No

* in combination with home automation

*** EU directive 2024/1103 2015/1186



Type of indication(s)		Trimline 120 Panoramic/Corner (1145-1146-1147)					
Appliance type		C11 C31 C91					
Balanced flue system		Holetherm CC 130 - 200					
Gas type		G25.3	G20		G20	G20=G25	G20/G25
Country		NL	AT/CH/CZ/DK/EE/ ES/ FI/GB/GR/HR/ HU/IE/IT/ LT/LV/N O/PT/RO/SE/SI/ SK/TR		DE/PL/RO	BE/FR	DE
Category		I2EK	I2H		I2E	I2E+	I2ELL
Primary air per burner		mm	2x(3xØ8mm)		2x(3xØ8mm)		
Symbol							
Pnom	Supply pressure	mbar	25	20	20	20=25	20
Pb-High	Burner pressure - high position	mbar	16,67	13,41	13,41	13,41=16,67	13,29
Pb-Low	Burner pressure - low position	mbar	7,76	6,35	6,35	6,35=7,76	6,08
Injector orifice		Ø mm	2xØ2,2		2xØ2,2		
Pilot flame injector		CODE	51		51		
Low position orifice		mm	1,8		1,8		
Qn	Load Hs	kW	13,43	14,16	14,16	14,16=13,43	11,53
Qn	Load Hi	kW	12,11	12,75	12,75	12,8=12,1	10,38
Vmax	Gas consumption	m³/h	1,457	1,349	1,349	1,349	1,278
Vpilot	Gas consumption	m³/h	0,0280	0,0270	0,0270	0,0270	0,0270
Pnom Hi	Nominal power - high position	kW	9,75	10,21	10,21	10,21	8,20
Pmin Hi	Nominal power - low position	kW	2,88	3,11	3,11	3,11	2,38
NOx classes			5	4	4	4	4
NOx Hs		mg/kWh	90,34	101,79	101,79	101,79	103,59

5 Pa min pressure in Flue system. conditions EN 613							
Tout	Flue gas Temp	C°	324,7		332,6		305,5
Tin	Air In Temp	C°	56,8		51,8		52,4
	CO ₂	%	6,2		6,4		5,3
ṁ	Mass flow	gr/sec	6,38		6,49		5,22

Rendement (NCV)							
η _{th.nom}	For nominal heat output	%	80,52	80,08	80,08	80,08	79,01
η _{th.min}	For minimal heat output	%	68,66	69	69	69	66,23
η _s	Seasonal energy efficiency for space heating	%	77,74	77,29	77,29	77,29	76,21

Additional electricity consumption (option)							
el _{max}	Nominal	kWh			0,0072		
el _{min}	Minimal	kWh			0,0003		
el _{sb}	Stand-by	kWh			0,0003		

Energy efficiency ***							
Energy efficiency index		EEL	78	77	77	77	76
Energy label			C	C	C	C	D

Type of heat output/room temperature control							
Indirect heat functionality							No
Single stage heat output, no room temperature control							No
2 or more manually-adjustable stages, no control of the room temperature							No
With mechanical control of room temperature by thermostat							No
With electronic control of room temperature							No
With electronic control of room temperature plus day-time switch							No
With electronic control of room temperature plus week-time switch							Yes

Other control options							
Control of room temperature with presence detection*							Yes
Control of room temperature with open window detection*							Yes
Distance control options*							Yes
Adaptive start control							No
Working time limitation							No
Black bulb sensor							No
Self-learning functionality							No
Control accuracy							No

* in combination with home automation

*** EU directive 2024/1103 2015/1186

V110526

Type of indication(s)			Trimline 120 Panoramic/Corner (1145-1146-1147)		
Appliance type			C11	C31	C91
Balanced flue system			Holetherm CC 130 - 200		
Gas type			G30/G31	G30	G30
Country			BE/CH/CY/CZ/ES/FR/GB/GR/IE/IT/LT/PT/SI/TR	CY/CZ/DK/EE/FI/GR/HR/HU/IT/LT/NL/NO/PL/RO/SE/SI/TR	Adjust when used AT/CH/DE/LU
Category			I3+	I3B/P	I3B/P (50mbar) If burnerpressure is 50mbar, adjust burner pressure high and low
Symbol	Primary air per burner	mm	2x(3xØ16mm)		
Pnom	Supply pressure	mbar	(28-30)-37	30	50
Pb-High	Burner pressure - high position	mbar	27,03	27,03	27,03
Pb-low	Burner pressure - low position	mbar	5,87	5,87	5,87
	Injector orifice	Ø mm	2xØ1,4		
	Pilot flame injector	CODE	30		
	Low position orifice	mm	1,3		
Qn	Load Hs	kW	13,87	13,87	13,87
Qn	Load Hi	kW	12,80	12,80	12,80
Vmax	Gas consumption	m³/h	0,397	0,397	0,397
Vmax	Gas consumption	kg/h	0,75	0,75	0,75
Vpilot	Gas consumption	m³/h	0,0075	0,0075	0,0075
Pnom Hi	Nominal power - high position	kW	9,60	9,60	9,60
Pmin Hi	Nominal power - low position	kW	3,22	3,22	3,22
	NOx classes		5	5	5
	NOx Hs	mg/kWh	44,59	44,59	44,59

5 Pa min pressure in Flue system. conditions EN 613			
Tout	Flue gas Temp	C°	336,7
Tin	Air InTemp	C°	39,8
	CO ₂	%	6,2
ṁ	Mass flow	gr/sec	6,98

Rendement (NCV)			
η _{th.nom}	For nominal heat output	%	75,02
η _{th.min}	For minimal heat output	%	63,98
η _s	Seasonal energy efficiency for space heating	%	72,44

Additional electricity consumption (option)			
el _{max}	Nominal	kWh	0,0072
el _{min}	Minimal	kWh	0,0003
el _{sb}	Stand-by	kWh	0,0003

Energy efficiency ***			
Energy efficiency index	EEL	72	72
Energy label		D	D

Type of heat output/room temperature control	
Indirect heat functionality	No
Single stage heat output, no room temperature control	No
2 or more manually-adjustable stages, no control of the room temperature	No
With mechanical control of room temperature by thermostat	No
With electronic control of room temperature	No
With electronic control of room temperature plus day-time switch	No
With electronic control of room temperature plus week-time switch	Yes

Other control options	
Control of room temperature with presence detection*	Yes
Control of room temperature with open window detection*	Yes
Distance control options*	Yes
Adaptive start control	No
Working time limitation	No
Black bulb sensor	No
Self-learning functionality	No
Control accuracy	No

* in combination with home automation

*** EU directive 2024/1103 2015/1186

Type of indication(s)		Trimline 140 Panoramic/Corner (1140-1141-1142)					
Appliance type		C11 C31 C91					
Balanced flue system		Holetherm CC 130 - 200					
Gas type		G25.3	G20		G20	G20=G25	G20/G25
Country		NL	AT/CH/CZ/DK/EE/ ES/ FI/GB/GR/HR/ HU/IE/IT/ LT/LV/N O/PT/RO/SE/SI/ SK/TR		DE/PL/RO	BE/FR	DE
Category		I2EK	I2H		I2E	I2E+	I2ELL
Primary air per burner		mm	2x(3xØ6mm)		2x(3xØ8mm)		
Symbol							
Pnom	Supply pressure	mbar	25	20	20	20=25	20
Pb-High	Burner pressure - high position	mbar	20,33	16,29	16,29	16,29=20,3	16,83
Pb-low	Burner pressure - low position	mbar	5,21	4,3	4,3	4,3=5,21	4,18
	Injector orifice	Ø mm	2xØ2,2		2xØ2,2		
	Pilot flame injector	CODE	51		51		
	Low position orifice	mm	2,2		2,2		
Qn	Load Hs	kW	15,24	15,85	15,85	15,85=15,24	12,67
Qn	Load Hi	kW	13,74	14,27	14,27	14,3=13,7	11,41
Vmax	Gas consumption	m³/h	1,653	1,51	1,51	1,51	1,404
Vpilot	Gas consumption	m³/h	0,0280	0,0270	0,0270	0,0270	0,0270
Pnom Hi	Nominal power - high position	kW	10,67	11,43	11,43	11,43	8,91
Pmin Hi	Nominal power - low position	kW	3,59	4,11	4,11	4,11	3,20
	NOx classes		5	5	5	5	5
	NOx Hs	mg/kWh	41,87	48	48	48	44,99

5 Pa min pressure in Flue system. conditions EN 613						
Tout	Flue gas Temp	C°	331		342,8	316,7
Tin	Air In Temp	C°	40,6		50,2	52,4
	CO ₂	%	5,8		6,7	5,3
ṁ	Mass flow	gr/sec	7,43		6,97	5,43

Rendement (NCV)							
η _{th.nom}	For nominal heat output	%	77,68	80,07	80,07	80,07	78,11
η _{th.min}	For minimal heat output	%	64,63	68,51	68,51	68,51	66,87
η _s	Seasonal energy efficiency for space heating	%	75,08	77,36	77,36	77,36	75,41

Additional electricity consumption (option)						
el _{max}	Nominal	kWh			0,0072	
el _{min}	Minimal	kWh			0,0003	
el _{sb}	Stand-by	kWh			0,0003	

Energy efficiency ***							
Energy efficiency index		EEL	75	77	77	77	75
Energy label			D	C	C	C	D

Type of heat output/room temperature control		
Indirect heat functionality		No
Single stage heat output, no room temperature control		No
2 or more manually-adjustable stages, no control of the room temperature		No
With mechanical control of room temperature by thermostat		No
With electronic control of room temperature		No
With electronic control of room temperature plus day-time switch		No
With electronic control of room temperature plus week-time switch		Yes

Other control options		
Control of room temperature with presence detection*		Yes
Control of room temperature with open window detection*		Yes
Distance control options*		Yes
Adaptive start control		No
Working time limitation		No
Black bulb sensor		No
Self-learning functionality		No
Control accuracy		No

* in combination with home automation

*** EU directive 2024/1103 2015/1186

V110526

Type of indication(s)			Trimline 140 Panoramic/Corner (1140-1141-1142)		
Appliance type			C11	C31	C91
Balanced flue system			Holetherm CC 130 - 200		
Gas type			G30/G31	G30	G30
			Adjust when used		
Country			BE/CH/CY/CZ/ES/FR/GB/GR/IE/IT/LT/PT/SI/TR	CY/CZ/DK/EE/FI/GR/HR/HU/IT/LT/NL/NO/PL/RO/SE/SI/TR	AT/CH/DE/LU
Category			I3+	I3B/P	I3B/P (50mbar)
			If burner pressure is 50mbar, adjust burner pressure high and low		
Symbol	Primary air per burner	mm	2x(3xØ16mm)		
Pnom	Supply pressure	mbar	(28-30)-37	30	50
Pb-High	Burner pressure - high position	mbar	26,35	26,35	26,35
Pb-low	Burner pressure - low position	mbar	10,64	10,64	10,64
	Injector orifice	Ø mm	2xØ1,35		
	Pilot flame injector	CODE	30		
	Low position orifice	mm	Ajustable		
Qn	Load Hs	kW	13,35	13,35	13,35
Qn	Load Hi	kW	12,32	12,32	12,32
Vmax	Gas consumption	m³/h	0,382	0,382	0,382
Vmax	Gas consumption	kg/h	0,72	0,72	0,72
Vpilot	Gas consumption	m³/h	0,0075	0,0075	0,0075
Pnom Hi	Nominal power - high position	kW	9,49	9,49	9,49
Pmin Hi	Nominal power - low position	kW	3,87	3,87	3,87
	NOx classes		5	5	5
	NOx Hs	mg/kWh	44,74	44,74	44,74

5 Pa min pressure in Flue system. conditions EN 613			
Tout	Flue gas Temp	C°	317
Tin	Air InTemp	C°	47,2
	CO ₂	%	6,1
ṁ	Mass flow	gr/sec	7,00

Rendement (NCV)			
η _{th.nom}	For nominal heat output	%	77,04
η _{th.min}	For minimal heat output	%	67,12
η _s	Seasonal energy efficiency for space heating	%	74,36

Additional electricity consumption (option)			
el _{max}	Nominal	kWh	0,0072
el _{min}	Minimal	kWh	0,0003
el _{sb}	Stand-by	kWh	0,0003

Energy efficiency ***			
Energy efficiency index	EEl	74	74
Energy label		D	D

Type of heat output/room temperature control	
Indirect heat functionality	No
Single stage heat output, no room temperature control	No
2 or more manually-adjustable stages, no control of the room temperature	No
With mechanical control of room temperature by thermostat	No
With electronic control of room temperature	No
With electronic control of room temperature plus day-time switch	No
With electronic control of room temperature plus week-time switch	Yes

Other control options	
Control of room temperature with presence detection*	Yes
Control of room temperature with open window detection*	Yes
Distance control options*	Yes
Adaptive start control	No
Working time limitation	No
Black bulb sensor	No
Self-learning functionality	No
Control accuracy	No

* in combination with home automation

*** EU directive 2024/1103 2015/1186

9 CONCENTRIC PATHWAYS

Concentric path table only to be used with the Holetherm balanced flue system.

Trimline 100 Panoramic/Corner (1156-1157-1158)

A

Horizontal lay out (NG-LPG)				
X-total min-max	Y-total min-max	Ø130 - Ø200		
		Baffle plate	Restrictor NG	Restrictor LPG
*1m	0,5	yes	55	80
1m	> 0,5 - 5,5	yes	0	0

*ηth.nom
min 0,5 = Wall transit

B

Vertical lay out (NG-LPG)			
X-total min-max	Ø130-Ø200 reduction after 1 metre Ø100 - Ø150		
	Baffle plate	Restrictor NG	Restrictor LPG
2-6m	yes	0	0
6-12m	yes	55	80

Always adhere to a starting length of 1 metre

C

Roof pass-through with 45° slope Ø130-Ø200 reduction after 1 metre Ø100-Ø150						
X-total min-max	Y-total min-max	Restrictor provision		Baffle plate	Restrictor NG	Restrictor LPG
		1m	0,5	X+X1+X2 - Y > 6 meter		ja
1m	> 0,5 - 5,5	X+X1+X2 - Y ≤ 6 meter		ja	0	0

Always adhere to a starting length of 1 metre

Example calculation image C

Step 1: calculate the chimney length

45-degree bend calculation length 1 metre

X	7m	Y-totaal	0,7m	Calculated length of bend
bend 45	1m			90° = 2m
X1	1m			45° = 1m
bend 45	1m			30° = 0,6m
X2	1,5m			15° = 0,3m
X-Total calculated	11,5m			

Step 2: calculate the Vertical X-Total ratio: Horizontal Y-total

Image D: Ratio Vertical : Horizontal (X+X1+X2) : Y ≥ 2 : 1

Y is for example 0.7 metres

(X+X1+X2) : Y ≥ 2:1	9,5 : 0,7 ≥ 2 : 1	X:Y ratio = allowed
---------------------	-------------------	---------------------

Step 3: determine restriction

	Baffle plate	Restrictor NG	Restrictor LPG
X+X1+X2 - Y > 6 meter	yes	55	80
X+X1+X2 - Y ≤ 6 meter	yes	0	0



Trimline 100 Panoramic/Corner (1156-1157-1158)

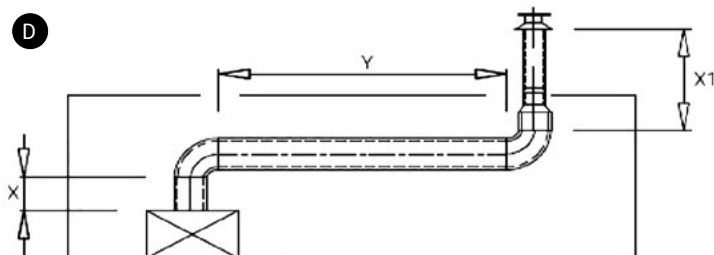

Roof pass-through with 90° slope Ø130-Ø200 reduction after last bend Ø100-Ø150

X-total min-max	Y-total min-max				
		Restrictor provision	Baffle plate	Restrictor NG	Restrictor LPG
3-12 m	0-2 m	$X+X1 - Y > 6$ meter	yes	55	80
3-12 m	0-2 m	$X+X1 - Y \leq 6$ meter	yes	0	0

Always adhere to a starting length of 1 metre

Example calculation image D

Step 1: calculate the chimney length

Y is bijvoorbeeld 3m

X	3 m	calculated length of bend
Bend 90	2 m	
Y	2 m	
Bend 90	2 m	
X1	1 m	
X-Total calculated	10	
		90° = 2 m
		45° = 1 m
		30° = 0,6 m
		15° = 0,3 m

Step 2: calculate the Vertical X-Total ratio: Horizontal Y-total

Image D: Ratio Vertical : Horizontal (X+X1):Y $\geq 2:1$

Y is for example 2 metres

$(X+X1) : Y \geq 2:1$	$4 : 2 \geq 2 : 1$	X:Y ratio = allowed
-----------------------	--------------------	---------------------

Step 3: bepaal restrictie

	Baffle plate	Restrictor NG	Restrictor LPG
$X+X1 - Y > 6$ meter	yes	55	80
$X+X1 - Y \leq 6$ meter	yes	0	0

Trimline 120 Panoramic/Corner (1145-1146-1147)

A

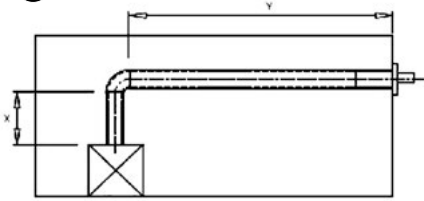

Horizontal lay out (NG-LPG)

X-total min-max	Y-total min-max	Ø130 - Ø200		
		Baffle plate	Restrictor NG	Restrictor LPG
*1m	0,5	yes	55	30
1m	> 0,5 - 5,5	yes	0	0

*min 0,5 = Wall transit

B

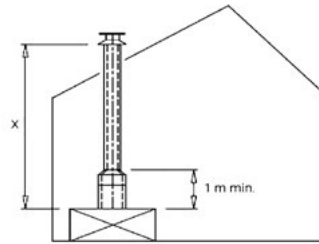

Vertical lay out (NG-LPG)

X-total min-max	Ø130-Ø200 reduction after 1 metre Ø100 - Ø150		
	Baffle plate	Restrictor NG	Restrictor LPG
2-6m	yes	0	0
6-12m	yes	55	30

Always adhere to a starting length of 1 metre

C

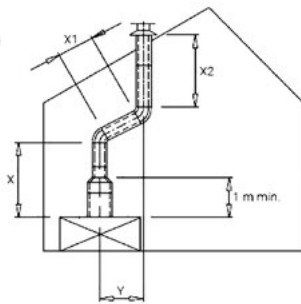

Roof pass-through with 45° slope Ø130-Ø200 reduction after 1 metre Ø100-Ø150

X-total min-max	Y-total min-max	Restrictor provision			
		Baffle plate	Restrictor NG	Restrictor LPG	
1m	0,5	X+X1+X2 - Y > 6 meter	ja	55	30
1m	> 0,5 - 5,5	X+X1+X2 - Y ≤ 6 meter	ja	0	0

Always adhere to a starting length of 1 metre

Example calculation image C

Step 1: calculate the chimney length

45-degree bend calculation length 1 metre

X	7m	Y-totaal	0,7m	Calculated length of bend
bend 45	1m			
X1	1m			90° = 2m
bend 45	1m			45° = 1m
X2	1,5m			30° = 0,6m
X-Total calculated	11,5m			15° = 0,3m

Step 2: calculate the Vertical X-Total ratio: Horizontal Y-total

Image D: Ratio Vertical : Horizontal (X+X1+X2) : Y ≥ 2 : 1

Y is for example 0.7 metres

(X+X1+X2) : Y ≥ 2:1	9,5 : 0,7 ≥ 2 : 1	X:Y ratio = allowed
---------------------	-------------------	---------------------

Step 3: determine restriction

	Baffle plate	Restrictor NG	Restrictor LPG
X+X1+X2 - Y > 6 meter	yes	55	30
X+X1+X2 - Y ≤ 6 meter	yes	0	0

Trimline 120 Panoramic/Corner (1145-1146-1147)

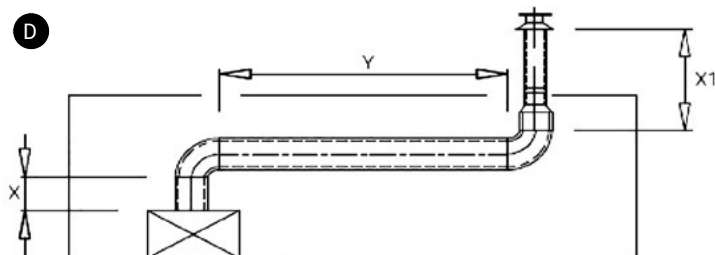

Roof pass-through with 90° slope Ø130-Ø200 reduction after last bend Ø100-Ø150

X-total min-max	Y-total min-max				
		Restrictor provision	Baffle plate	Restrictor NG	Restrictor LPG
3-12 m	0-2 m	$X+X1 - Y > 6$ meter	yes	55	30
3-12 m	0-2 m	$X+X1 - Y \leq 6$ meter	yes	0	0

Always adhere to a starting length of 1 metre

Example calculation image D

Step 1: calculate the chimney length

Y is bijvoorbeeld 3m

X	3 m	calculated length of bend
Bend 90	2 m	
Y	2 m	
Bend 90	2 m	
X1	1 m	
X-Total calculated	10	
		90° = 2 m
		45° = 1 m
		30° = 0,6 m
		15° = 0,3 m

Step 2: calculate the Vertical X-Total ratio: Horizontal Y-total

Image D: Ratio Vertical : Horizontal (X+X1):Y $\geq 2:1$

Y is for example 2 metres

$(X+X1) : Y \geq 2:1$	$4 : 2 \geq 2 : 1$	X:Y ratio = allowed
-----------------------	--------------------	---------------------

Step 3: bepaal restrictie

	Baffle plate	Restrictor NG	Restrictor LPG
$X+X1 - Y > 6$ meter	yes	55	30
$X+X1 - Y \leq 6$ meter	yes	0	0

Trimline 140 Panoramic/Corner (1140-1141-1142)

A

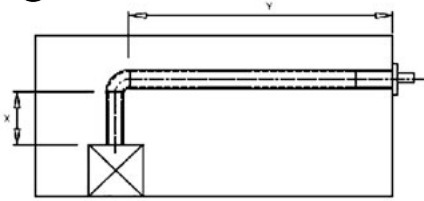

Horizontal lay out (NG-LPG)

X-total min-max	Y-total min-max	Ø130 - Ø200		
		Baffle plate	Restrictor NG	Restrictor LPG
*1m	0,5	yes	55	50
1m	> 0,5 - 5,5	yes	0	0

Note: Remove the G25.3 air distributor **APPENDIX 4 7 8**
 *ηth.nom
 min 0,5 = Wall transit

B

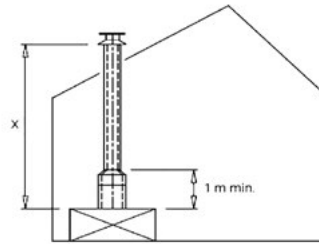

Vertical lay out (NG-LPG)

X-total min-max	Ø130-Ø200 reduction after 1 metre Ø100 - Ø150		
	Baffle plate	Restrictor NG	Restrictor LPG
2-6m	yes	0	0
6-12m	yes	55	50

Always adhere to a starting length of 1 metre

C

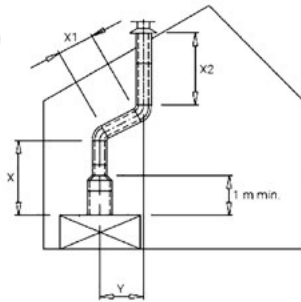

Roof pass-through with 45° slope Ø130-Ø200 reduction after 1 metre Ø100-Ø150

X-total min-max	Y-total min-max	Restrictor provision			
		Baffle plate	Restrictor NG	Restrictor LPG	
1m	0,5	X+X1+X2 - Y > 6 meter	ja	55	50
1m	> 0,5 - 5,5	X+X1+X2 - Y ≤ 6 meter	ja	0	0

Always adhere to a starting length of 1 metre

Example calculation image C

Step 1: calculate the chimney length

45-degree bend calculation length 1 metre

X	7m	Y-totaal	0,7m	Calculated length of bend
bend 45	1m			90° = 2m
X1	1m			45° = 1m
bend 45	1m			30° = 0,6m
X2	1,5m			15° = 0,3m
X-Total calculated	11,5m			

Step 2: calculate the Vertical X-Total ratio: Horizontal Y-total

Image D: Ratio Vertical : Horizontal (X+X1+X2) : Y ≥ 2 : 1

Y is for example 0.7 metres

(X+X1+X2) : Y ≥ 2:1	9,5 : 0,7 ≥ 2 : 1	X:Y ratio = allowed
---------------------	-------------------	---------------------

Step 3: determine restriction

	Baffle plate	Restrictor NG	Restrictor LPG
X+X1+X2 - Y > 6 meter	yes	55	50
X+X1+X2 - Y ≤ 6 meter	yes	0	0

Trimline 140 Panoramic/Corner (1140-1141-1142)

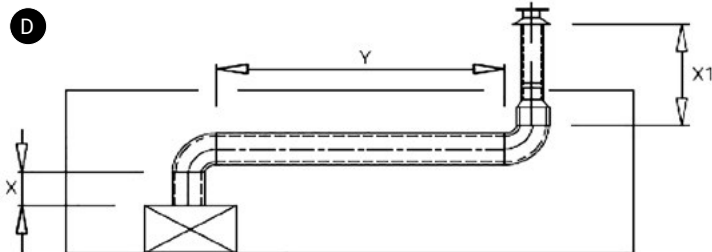

Roof pass-through with 90° slope Ø130-Ø200 reduction after last bend Ø100-Ø150

X-total min-max	Y-total min-max				
		Restrictor provision	Baffle plate	Restrictor NG	Restrictor LPG
3-12 m	0-2 m	$X+X1 - Y > 6$ meter	yes	55	50
3-12 m	0-2 m	$X+X1 - Y \leq 6$ meter	yes	0	0

Always adhere to a starting length of 1 metre

Example calculation image D

Step 1: calculate the chimney length

Y is bijvoorbeeld 3m

			calculated length of bend
X	3 m		
Bend 90	2 m		90° = 2 m
Y	2 m		45° = 1 m
Bend 90	2 m		30° = 0,6 m
X1	1 m		15° = 0,3 m
X-Total calculated	10		

Step 2: calculate the Vertical X-Total ratio: Horizontal Y-total

Image D: Ratio Vertical : Horizontal (X+X1):Y ≥ 2:1

Y is for example 2 metres

$(X+X1) : Y \geq 2:1$	$4 : 2 \geq 2 : 1$	X:Y ratio = allowed
-----------------------	--------------------	---------------------

Step 3: bepaal restrictie

	Baffle plate	Restrictor NG	Restrictor LPG
$X+X1 - Y > 6$ meter	yes	55	50
$X+X1 - Y \leq 6$ meter	yes	0	0

10 CONCENTRIC FLUE SYSTEM

The concentric flue system is composed of an inner flue and an outer flue. These flues have been set up concentrically so the combustion gases will be discharged via the internal flue while the fresh combustion air is supplied via the gap between the inner and outer flues.

10.1 Components of the concentric flue system

Different connections are possible using the concentric flue system. These are:

Through the roof face and through the exterior wall

The pathway used for this system can be laid in different ways, but there are a few important conditions:

- 1 The total allowed vertical flue length must not exceed 12 metres (the sum of the flue length and calculation lengths for the bends). See *Chapter 9 Concentric pathways*.
- 2 90° bends have a 2-metre horizontal calculation length.
- 3 45° bends have a 1-metre horizontal calculation length.
- 4 The outlet can be installed at any point on the roof face or exterior wall (supply and discharge in an identical pressure area), but must meet applicable regulations.
- 5 Flue pathways must not be insulated.

NOTE

- 1 Ensure the restrictor is mounted in the correct manner, as indicated in these instructions.
- 2 The correct restrictor will provide the appliance with the most optimal efficiency, flame image and combustion.
- 3 Mounting an incorrectly placed restrictor may cause malfunction of the appliance.

10.2 Construction of concentric flue system

Indirect wall connection

- 1 The outlet may also be installed in an upwards exhaust in the wall, taking any hindrance to the surrounding area into consideration, in accordance with local standards and regulations.

NOTE

Ensure wind pressure on the outlet is not excessive, such as in locations with a balcony, flat roof, corners and very narrow alleys, etc., as this can negatively affect the performance of the appliance.

- 2 Make a recess in the façade of around 155mm or 205mm when using respectively Ø100-150 and Ø130-200 flues (keep an extra space of 50mm in a refractory façade around the outer tube) and fit the façade pass-through with the wall plate on the inside of the wall. The wall plate of the exterior façade pass-through must be sealed sufficiently against the wall on the outside to avoid moisture and/or flue gas leaks leaking into the living space. We recommend our clearance box use as a direct façade pass-through through a refractory façade.

- 3 The flue should be encased if necessary. Even if the flue is to be installed along non-refractory materials, sufficient fire-resistant measures must be taken.
- 4 Determine the position of the appliance and outlet and begin construction of the flue with the connection on the appliance, paying attention to the direction of installation and connecting the elements by means of clamp strips.
- 5 An adjustable pipe can be used between the bends or when connecting to the appliance. If necessary, use wall brackets to support the flue.

Mounting using the roof pass-through option

- 6 The flue outlet can be located at any random place on the roof face (supply and exhaust in identical pressure areas) and must meet the applicable rules and regulations.
- 7 A roofing sheet for a flat roof or a roofing sheet lead for sloping tiled roofs can be used for a watertight duct. Use various bends for the slope, if required. The recess in the roof decking should be 50mm larger all around to ensure sufficient fire resistance.
- 8 One needs to take into account the regulation regarding fire resistance between rooms. (For this, see the applicable local standards and regulations.) A casing of fireproof material (for example, 12mm Promatect fire-resistant plate) should be applied up to 25mm from the outer flue.
- 9 Determine the position of the appliance and the outlet and begin the construction of the flue with the connection on the appliance (always 1 metre vertical first) pay attention to the direction of installation. The inner flue must be installed for draining purposes. Connect the elements using the clamping straps. Ensure all connections are gastight.
- 10 An adjustable pipe can be used between the bends or when making the connection to the appliance and/or the roof pass-through. Use 2 wall brackets to support the flue on each floor.

10.3 Installation instructions regarding existing flues

APPENDIX 3

Instructions

The flue gas exhaust system falls within category: C91 and must be built in accordance with national rules and regulations and the instructions of the manufacturer, as specified in the documentation and installation instructions. This means, among other things, that the chimney pass-through must not be smaller than 150mm round/square, but no larger than 200mm, and not ventilated by grilles, etc. In the case of larger chimney pass-throughs, a flexible hose of around 150 mm may possibly be used in combination with a flexible hose of around 100mm, as described below. For other situations, consult your supplier.

10.4 Parts

Check all parts for damage before commencing the installation. For the conversion of a brick flue to concentric flue, connected to CC flue system, you need the components described in [APPENDIX 3](#).

NOTE

The renovation/sanitation set consists of parts:

- ③ Interior mounting plate
- ④ Sliding element
- ⑦ Chimney mounting plate

10.5 Installation

- 1 Guide the flexible hose ⑤ through the existing flue ⑥.
- 2 Attach the slider ④ to the bottom of the flexible hose and secure this in place using two Parker screws.
- 3 Keep the bottom of the slider at the same height as the bottom of the flue or ceiling.
- 4 Shorten the flexible hose to approximately 100mm above the chimney coping.
- 5 Attach the mounting plate to the flexible hose on the roof ⑦, clamp it with a hose bracket. Stainless steel Ø90 to 165mm, secure the whole with Parker screws.
- 6 Attach the mounting plate to the chimney coping watertight on the roof ⑦ using silicone sealant and stainless steel screws.
- 7 Install the roof pass-through ⑨ and secure it in place using the supplied clamping strip ⑧.
- 8 The slider ④ will protrude approximately 100mm underneath the flue or ceiling after installation.
- 9 Attach the inner mounting plate ③ gastight against the bottom of the structural flue or against the bottom of the concrete floor using silicone sealant and screws.
- 10 Position the appliance in accordance with the instructions of the appliance manufacturer
- 11 Install a minimum of 1 metre of concentric flue type THC CC ①.
- 12 Extend the concentric flue using sections up to a minimum of 100mm in the structural duct. Finally, turn the clamping strip by hand in the mounting plate inside ③.

11 PASS-THROUGH POSITIONS AND FUNCTION CORRECTLY

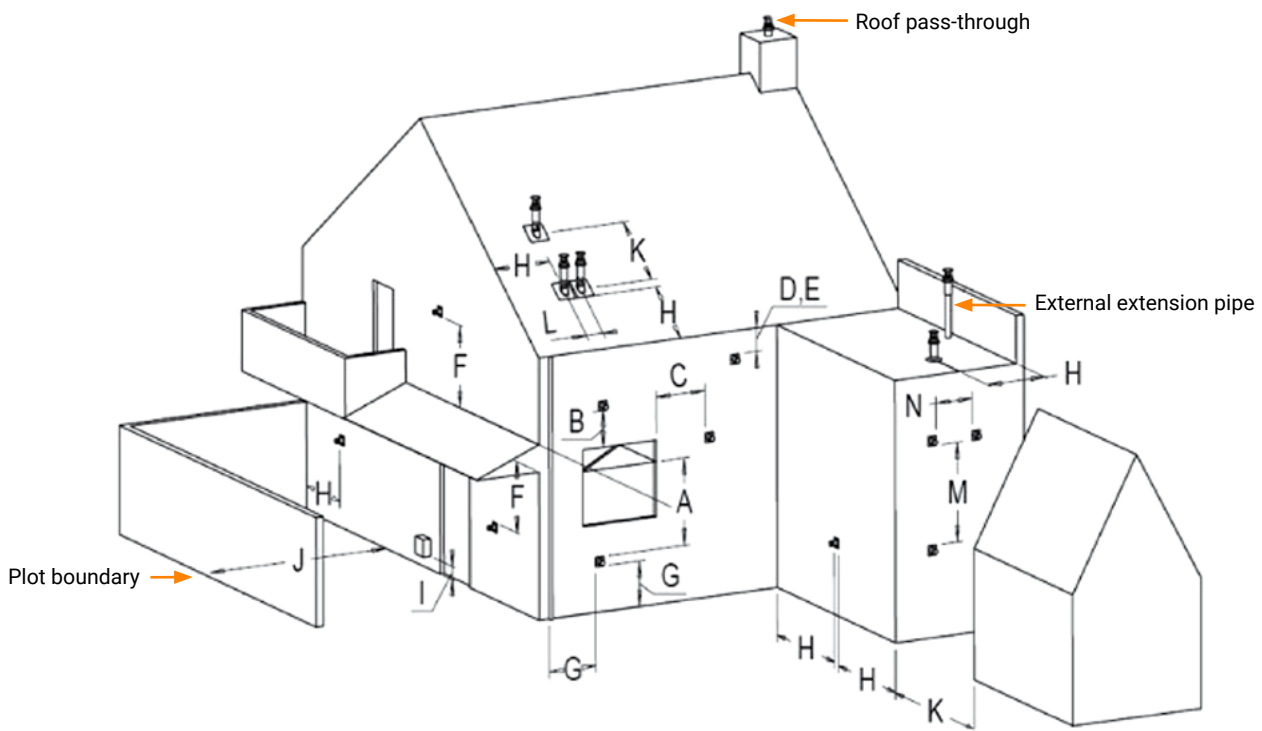

Dimensions	Outlet positions	Distance mm
A	Distance to ventilation openings	Local*
B	Distance to ventilation openings	Local*
C	Distance to ventilation openings	Local*
D	Lower gutter bottom pipes or exhaust lines	500
E	Under the eaves	500
F	Under a carport, roof or balcony, inside and outside corners	500
G	From ground level and rainwater drainage pipes	300
H	Inside and outside a corner	500
I	Above an external gas pressure regulator	1000
	Side of a gas pressure regulator	500
J	Conflict distance façade outlet	Local*
K	Roof drain centre to centre	1000
L	From the centre of both roof drains	450
M	Two wall drains above each other	1000
N	Two wall drains next to each other	1000

* In accordance with local building codes

12 CLEANING AND MAINTENANCE

- 1 The appliance must be checked and serviced by a recognised installer at least once a year. The glass is also cleaned during this process.
- 2 It is advisable to clean the outside of the appliance regularly, both in and out of the heating season.
- 3 Do not use aggressive or corrosive cleaning agents or sharp objects.
- 4 The concentric flue system must be cleaned every 2 years.

A check must be carried out on:

 - a seal of the flue and supply circuits
 - b seal of the upper and lower pressure release hatches of the appliance; check the gasket
 - c operation of the pressure release hatches; that they can open and close freely
 - d the operation of the gas valve and ignition of the burner

Measuring points

The appliance is equipped with measuring points to analyse the combustion gases and fresh combustion air. This allows the appliance to be checked. The connection points are located in the middle of the glass holder above the front glass panel. To connect the measuring tubes, remove the sealing plugs first using a 5 mm Allen key. The left-hand connection is for the fresh combustion air, the right-hand connection is for the combustion gases.

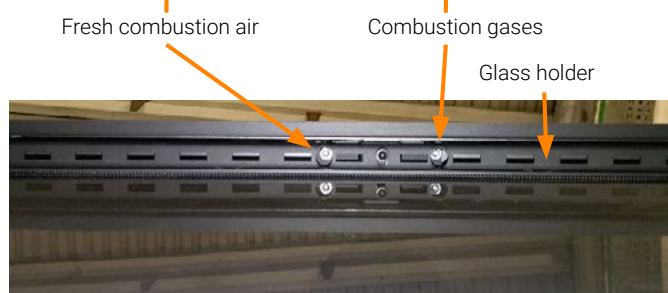

13 QUICK REFERENCE GUIDE FOR FAULTSSEARCH FOR ENCLOSED GAS FIRES USING MERTIK GV60 GASCONTROL

Function	Possible cause	Solution
1. Acoustic signals	1 long beep → reset switch OFF (0)	Set switch to (I)
	1 long beep → connections not complete	Check connections in thermocouple circuit
	1 long beep → 8-core cable defective	Check connections in connector/replace 8-core cable
	1 long beep → micro switch defective	Replace gas valve
	1 long beep → Sync not OK	Carry out new sync procedure for remote control/receiver
	3 short beeps → power supply	Replace batteries or 6-VDC adapter
2. No reaction remote control/receiver	Power supply problem	Check batteries/6-VDC adapter
	No sync remote/receiver	Carry out sync procedure
	Distance between remote control/receiver	Change position of receiver
	Defective receiver	Replace receiver
	Faulty remote control	Replace remote control
3. No pilot light gas	GV60 DC magnet unit does not open (no clicking noise from gas valve)	<ul style="list-style-type: none"> • Check wiring and breaker on thermocouple circuit • Check/replace 8-core cable between remote control and gas valve • 1 x sparks and stop: check ground cable under torx gas valve • Replace receiver • Replace gas valve
4. Poor/no spark	Spark cable loose	Check spark cable connections
	Short circuit between cable and metal	Check whether cable is free of metal parts
	Poor spark candle	Check spark candle for fractures, replace if necessary
	Distance of sparking candle to pilot light head	Check distance is approximately 4mm
5. Pilot light difficult to ignite	Gas supply pressure too high, nervous flame	Adjust gas supply pressure or adjust the pilot light pressure using the gas valve
	Gas supply pressure too low, short flame	Adjust gas supply pressure, check gas pipes, or adjust pilot light pressure using the gas valve
	Air in (pilot light) pipe, flame on/off	Blow pipes through, make air-free
	Injector blocked	Clean or replace pilot light injector
	Blocked/curved pilot light pipe	Check and clean pipe
	Pilot light head damaged	Check and replace pilot light
6. Pilot light goes out after ignition	Small pilot light, no flame on thermocouple tip	Check gas supply pressure, possibly too low
		Check pilot light injector and gas pipe
	Nervous pilot light flame, no flame on thermocouple tip	Check gas supply pressure, too high, adjust
		Adjust pilot light pressure on gas control block
	Air in pipes, vent	
	Lazy pilot light, no flame on thermocouple tip	Check premix opening on pilot light, must be open
	Poor connections in thermocouple circuit	Check cables/breaker in thermocouple circuit
		Check thermocouple connections in gas control block, do not over-tighten.
		Measure thermocouple circuit voltage 4.5mV minimum
Bad thermocouple	Check open circuit voltage of thermocouple (18-30mV), replace if necessary	
Poor DC magnet unit in GV60	Replace gas valve	
7. Pilot light goes out when the fireplace is closed	False air along pilot light holder/gasket	Check pilot light holder and gasket for leaks
	False air hatches	Check pressure hatches/gasket is completely closed
	Main flame causes pilot light to go out	Check restriction/baffle in accordance with regulations

Function	Possible cause	Solution
8. Pilot light/main flame off	Gas pre-pressure has dropped	Check correct dimensions of gas pipe or blockage, correct
	Main burner ignition, 3 beeps, low power supply voltage	Check batteries or 6-VDC adapter
	Too much/little transport in unit/outlet	Check restriction/baffle situation in accordance with instructions.
	Concentric outlet pathway incorrect	Check outlet pathway in accordance with instructions
	Recirculation, façade/roof mouth position incorrect	Check outlet in accordance with instructions
	Recirculation in closed outlet system	Check outlet connections
9. Main burner does not start up	Gas control valve knob to MAN	Check gas control valve knob to ON
10. Delayed ignition of main burner	Pilot light burner blocked	Check logs, pebbles, etc. are in the right position. pilot light should be free of obstructions.
	Small/lazy pilot light	Check and correct pressure and physical state of pilot light burner
	Close main burner flame openings	Check and clean with a vacuum cleaner or similar device.
	Logs, etc. in wrong position	Check and correct, see instructions
11. Low main flame	Gas supply pressure too low	Check gas supply pressure and corrections
	Burner pressure too low	Check burner pressure, check instructions for correct values
12. No or little difference between high/low settings for main flame	Low position setting incorrect	Check and adjust low position in accordance with instructions
13. DB burner does not work	Defective step valve	Check whether clicking sound is perceptible, press button on remote control several times, replace valve if necessary
14. Sooty flame	Insufficient transport in unit/closed drainage system	Check restriction/baffle, follow instructions for correct value
		Check outlet system pathway in accordance with instructions
		Check outlet in accordance with regulations/instructions
	Excessive feed/burner pressure	Check and correct gas supply/burner pressure in accordance with instructions
	Blocked burner flame openings	Check and clean with a vacuum cleaner, for example
	Incorrect premix for main burners	Check and correct, see instructions
	Decorative logs, etc. in incorrect position	Check and correct, see instructions

Appendix 1 DIMENSIONAL DRAWINGS

Measurements in mm

1156/1145/1140 Panoramic

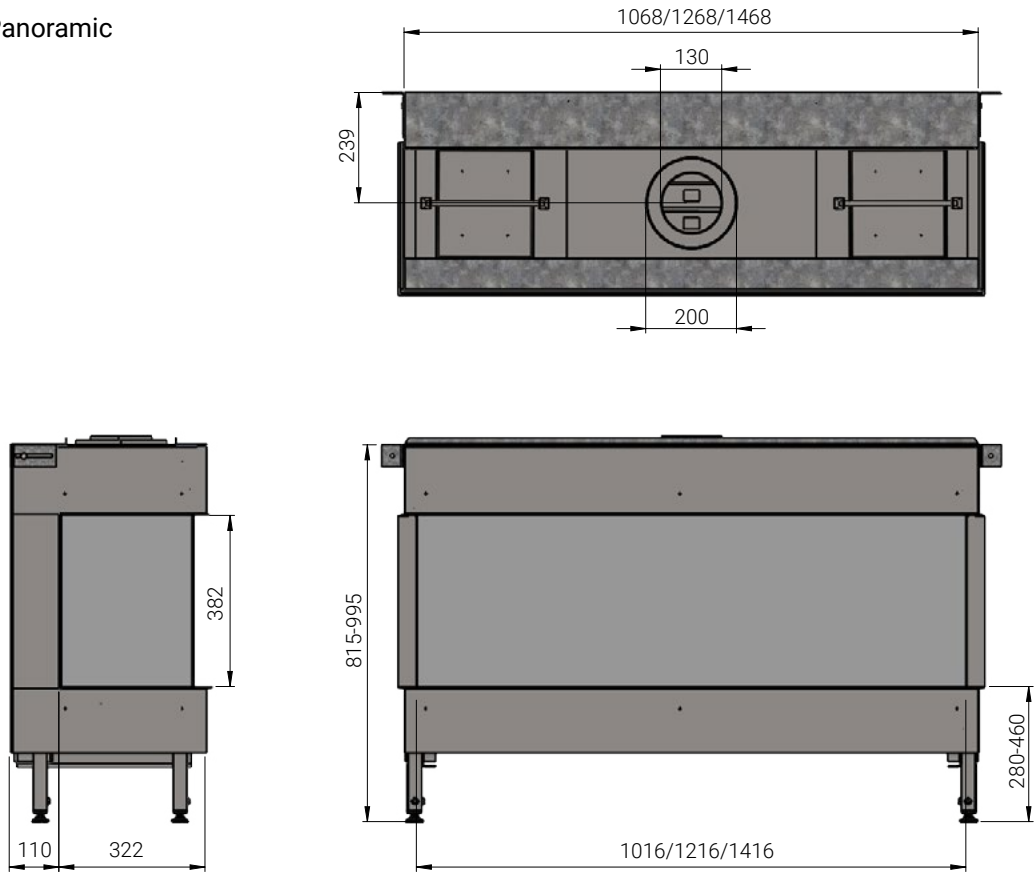

1157-1158 /1146-1147/1141-1142 Corner Left - Right

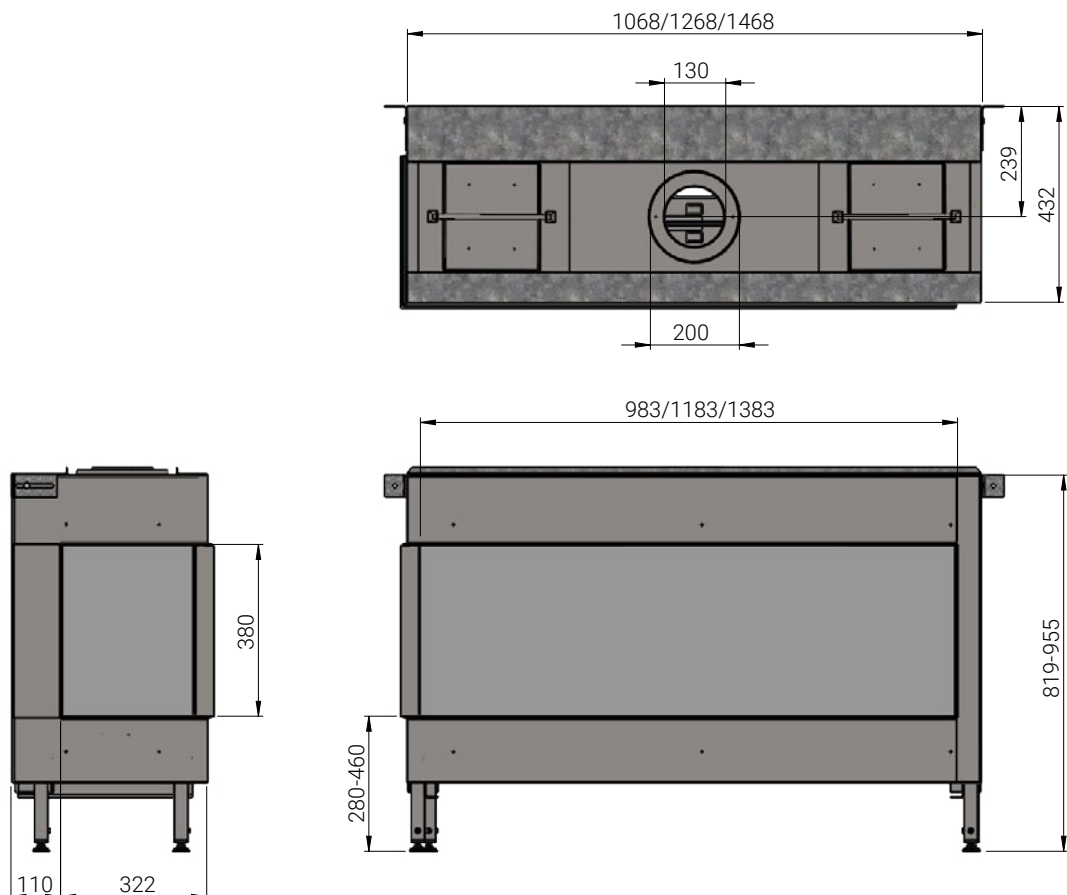

V110526



Appendix 1 CONTINUED

Measurements in mm

Built-in cassette

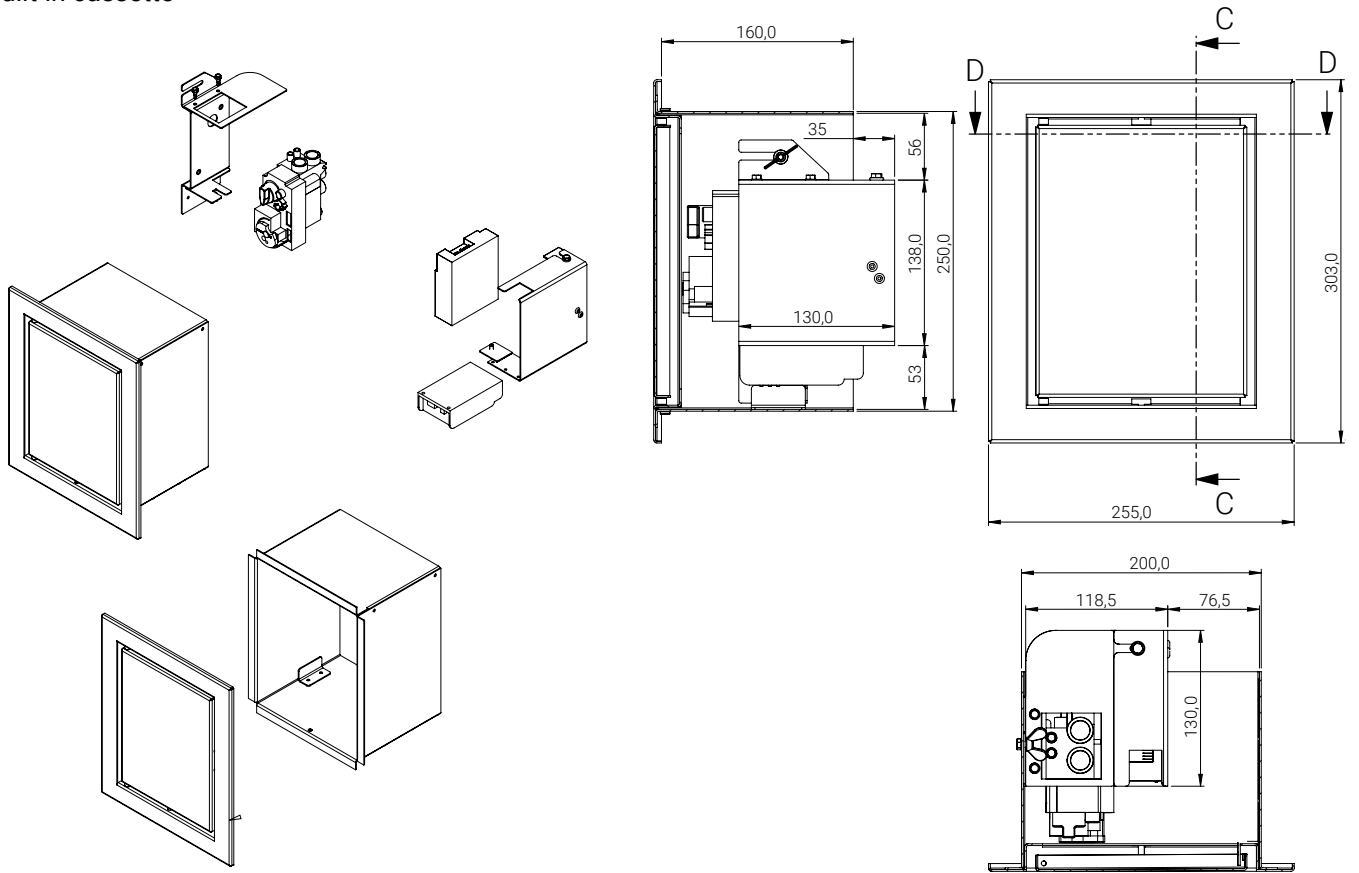

Convection grilles

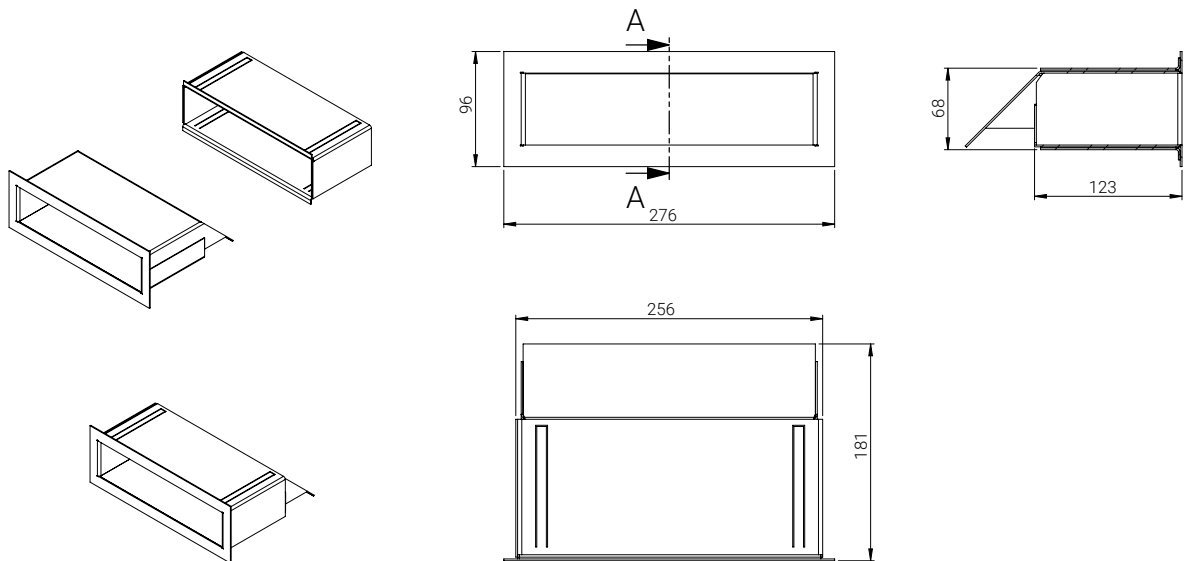

V110526



Appendix 2 BUILT-IN EXAMPLES

Measurements in mm

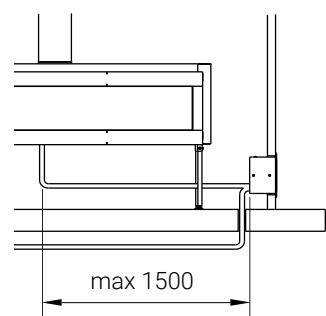
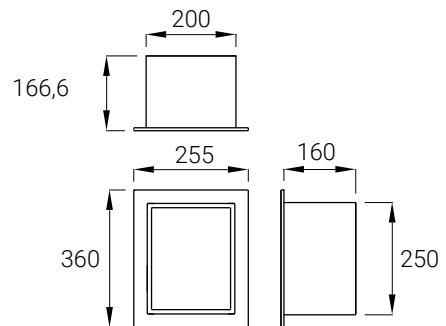
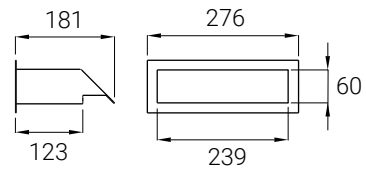
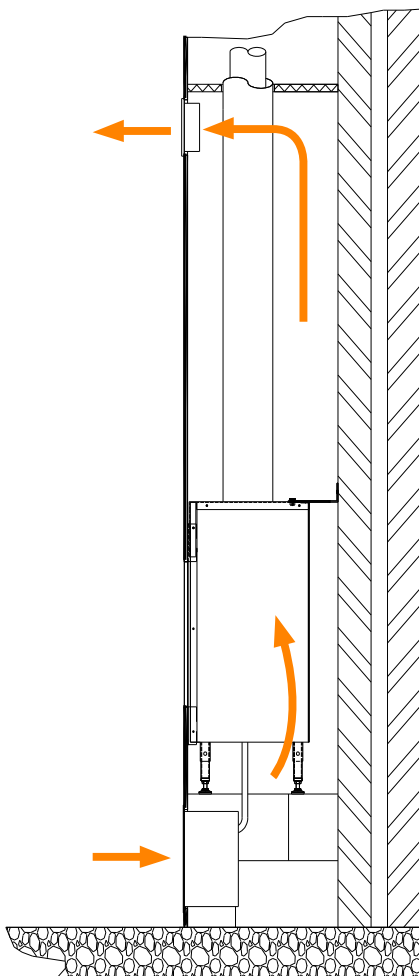
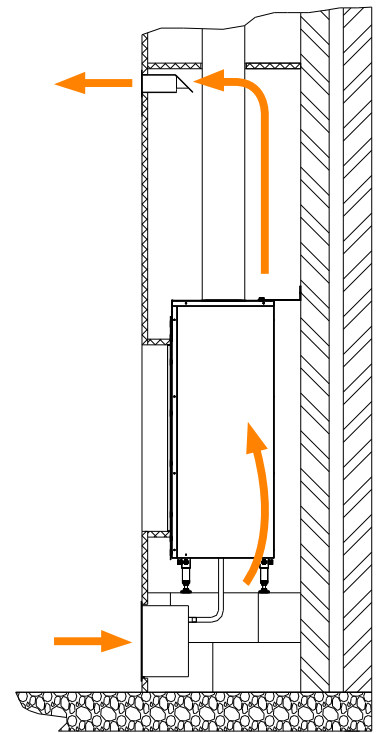
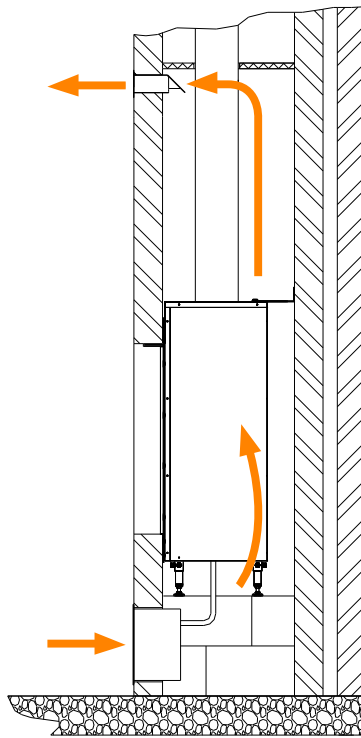
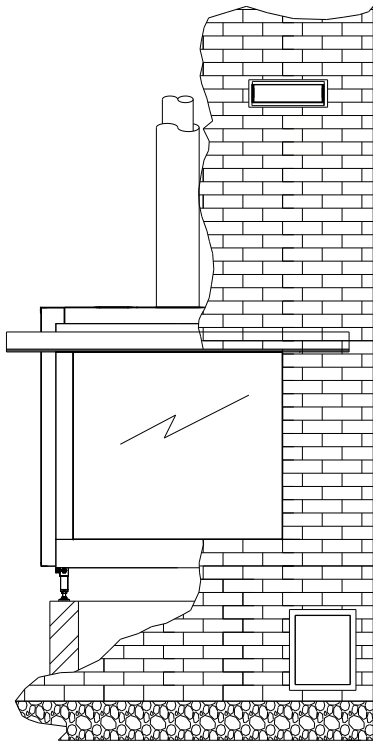

V110526



Appendix 3 CONSTRUCTION DIAGRAM DOUBLE-WALL CONCENTRIC

Material: Stainless steel AISI 316 L - Allow number 1.4404

Application: for the discharge of flue gases and the supply of combustion air from gas-fired appliances or stoves with a closed combustion system

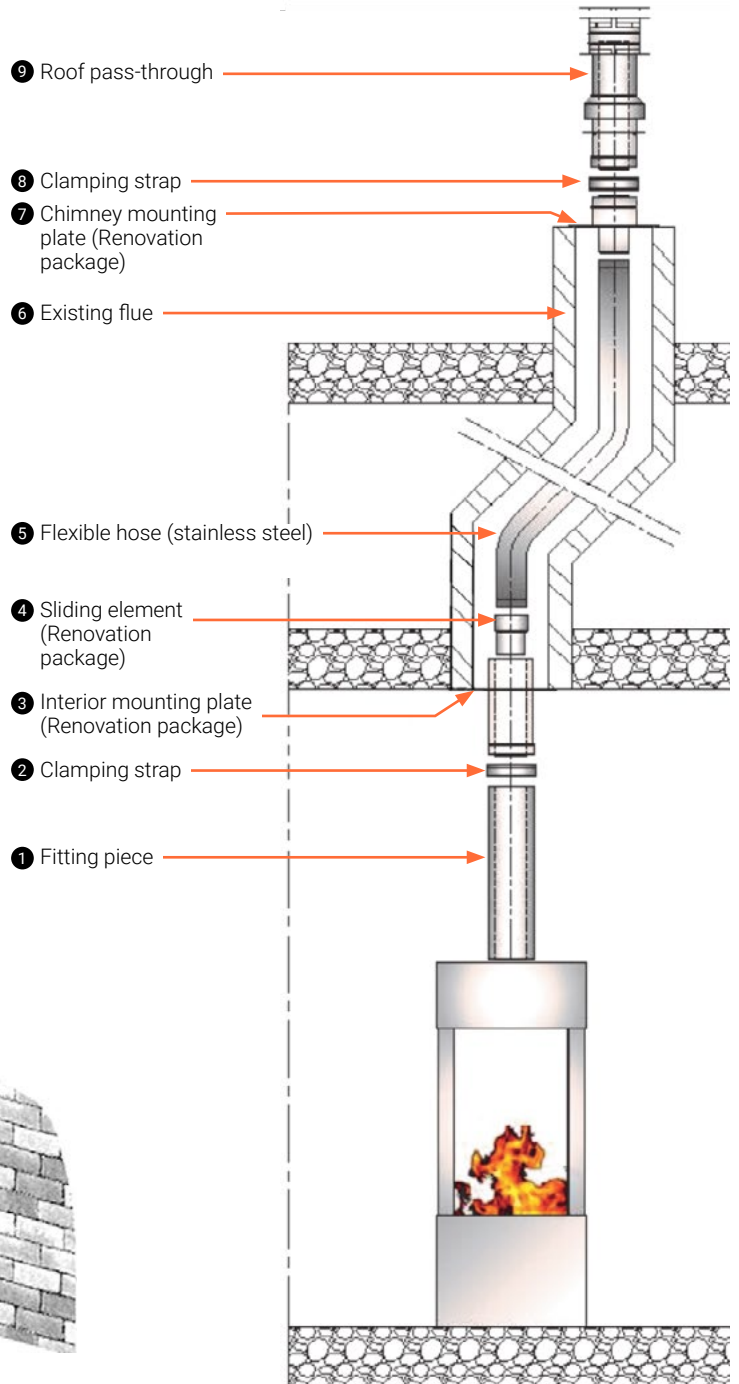
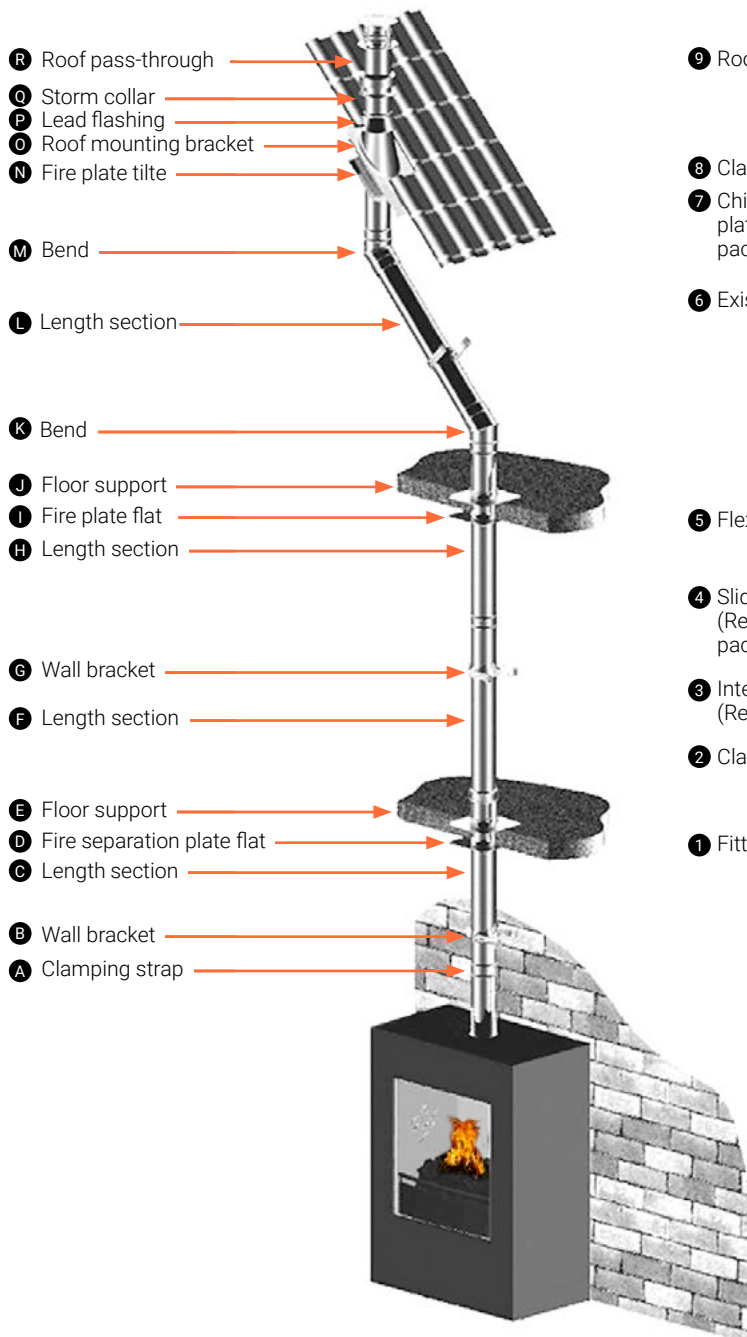

Appendix 4 PREPARATION AND INSTALLATION

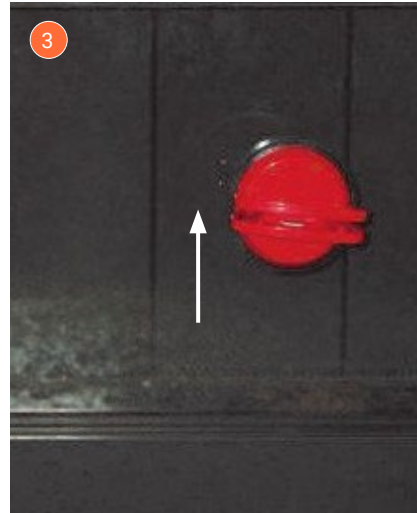

Removing the air distributor – for G25.3 Trimline 140 Panoramic/ Corner (1140-1141-1142) only
Remove the mounting screws (see arrows) and then remove the air distributor. After removing the air distributor, reinstall the mounting screws.



Air distributor removed.

V110526



Appendix 5 PREPARING GAS CASSETTE GV60 FOR INSTALLATION

STEP 1 ①

Cut the ties to release all lines. ①

STEP 2 ①

Remove the protection bracket with gas control block and receiver. ②

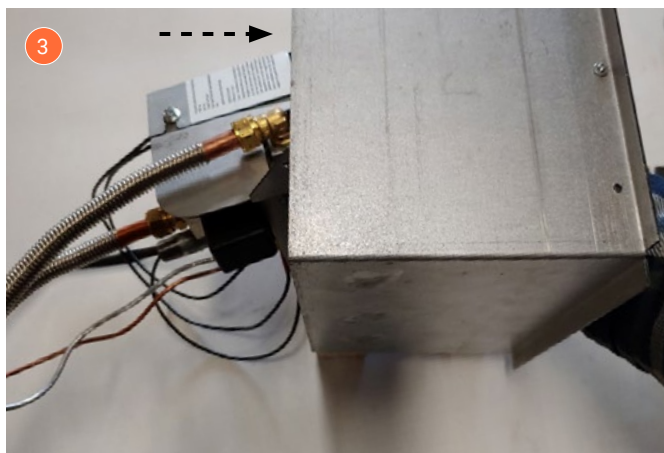
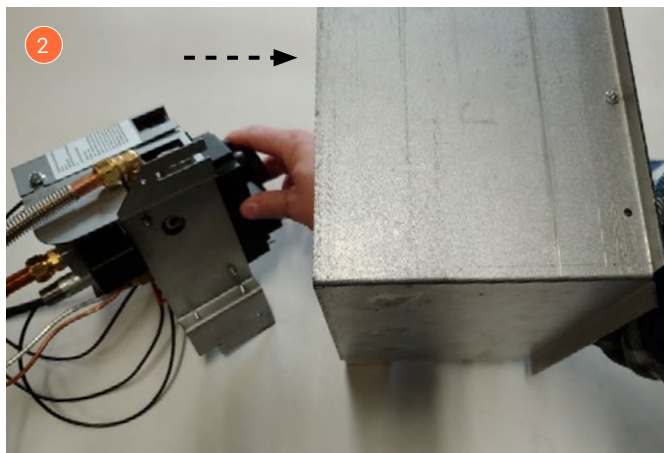
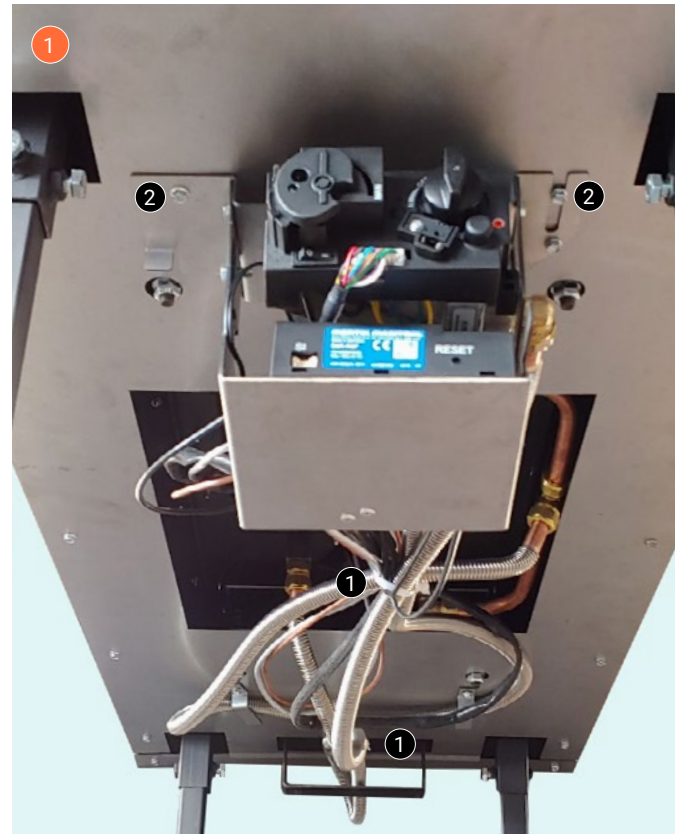

STEP 3 ② ③ ④

Place the gas control block and receiver in the gas cassette.

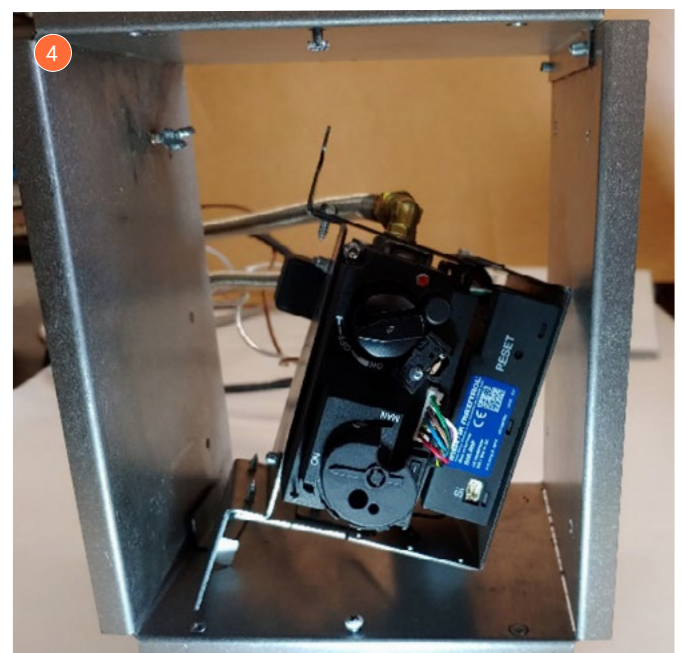

Appendix 5 CONTINUED

STEP 4 5 6 7

Slide the bracket with the gas control block and receiver into place ①. Fix the wing nuts in place. ②

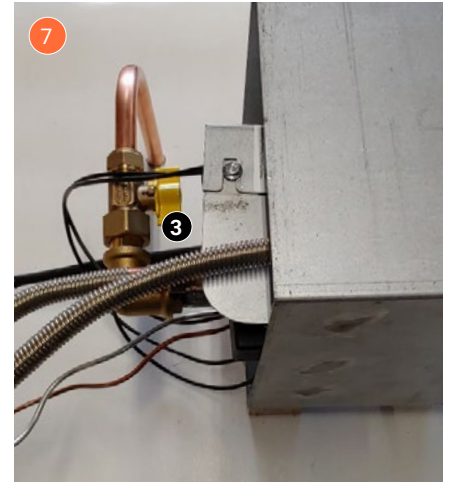
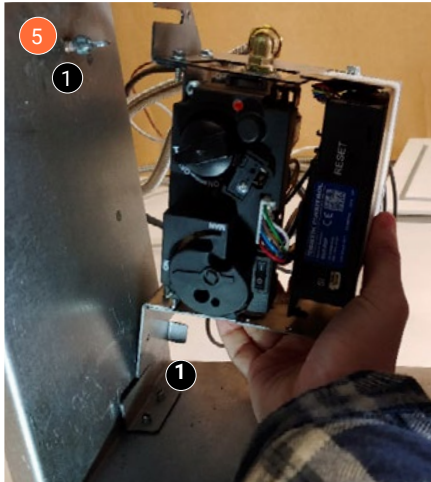

Example of installing an accessible tap. ③

Appendix 6 EXPLODED VIEW AND SPARE PARTS

No	Description	Artikel Number	Quantity
1	Combustion chamber	x	1
2	Burner	on request	1
3	Bottomplate burnertray	x	1
4	Decoration plate	x	1
5	Pilot bracket	x	1
6	Injector bracket	x	1
7	Pilot burner	642200432	1
8	Pressure hatch plate	x	1
9	Seal pressue hatch plate 3mm	x	1
10	Pressure hatch spring	x	1
11	Top Pressure hatch plate	x	1
12	Top Seal pressue hatch plate 5mm	x	1
13	Glass panel front 100 panoramic	421410110410	1
	Glass panel front 100 corner	421410050410	1
	Glass panel front 120 panoramic	421412110411	1
	Glass panel front 120 corner	421412050411	1
	Glass panel front 140 panoramic	421414110410	1
Glass panel front 140 corner	421414050410	1	
14	Glass panel side	421403100410	1 or 2
Set:	Glasstrip set 100 panoramic	531101156	1
15	Glasstrip set 100 corner L	531101157	1
16	Glasstrip set 100 corner R	531101158	1
17	Glasstrip set 120 panoramic	531101145	1
18	Glasstrip set 120 corner L	531101146	1
28	Glasstrip set 120 corner R	531101147	1
29	Glasstrip set 140 panoramic	531101140	1
30	Glasstrip set 140 corner L	531101141	1
	Glasstrip set 140 corner R	531101142	1

No	Description	Artikel Number	Quantity
Set:	Flat decostrip set 100 panoramic	531201156	1
15	Flat decostrip set 100 corner L	531201157	1
16	Flat decostrip set 100 corner R	531201158	1
17	Flat decostrip set 120 panoramic	531201145	1
18	Flat decostrip set 120 corner L	531201146	1
28	Flat decostrip set 120 corner R	531201147	1
29	Flat decostrip set 140 panoramic	531201140	1
30	Flat decostrip set 140 corner L	531201141	1
	Flat decostrip set 140 corner R	531201142	1
19	Restrictor plate	x	1
20	Interior back panel/label	x	1
21	Baffle plate	x	1
22	Convection mantle front/side	x	1
23	Spring glass block	x	2 or 4
24	Convection mantle back	x	1
25	Convection mantle top	x	1
26	Wall bracket	x	1
27	Adjustable feet	x	1
	Convection grill	117042000150	1
	Glass panel seal 8 x 2mm self adh	721000118	per m
	Spray paint senotherm 12-1644-702310 400ml 5	562001160	1

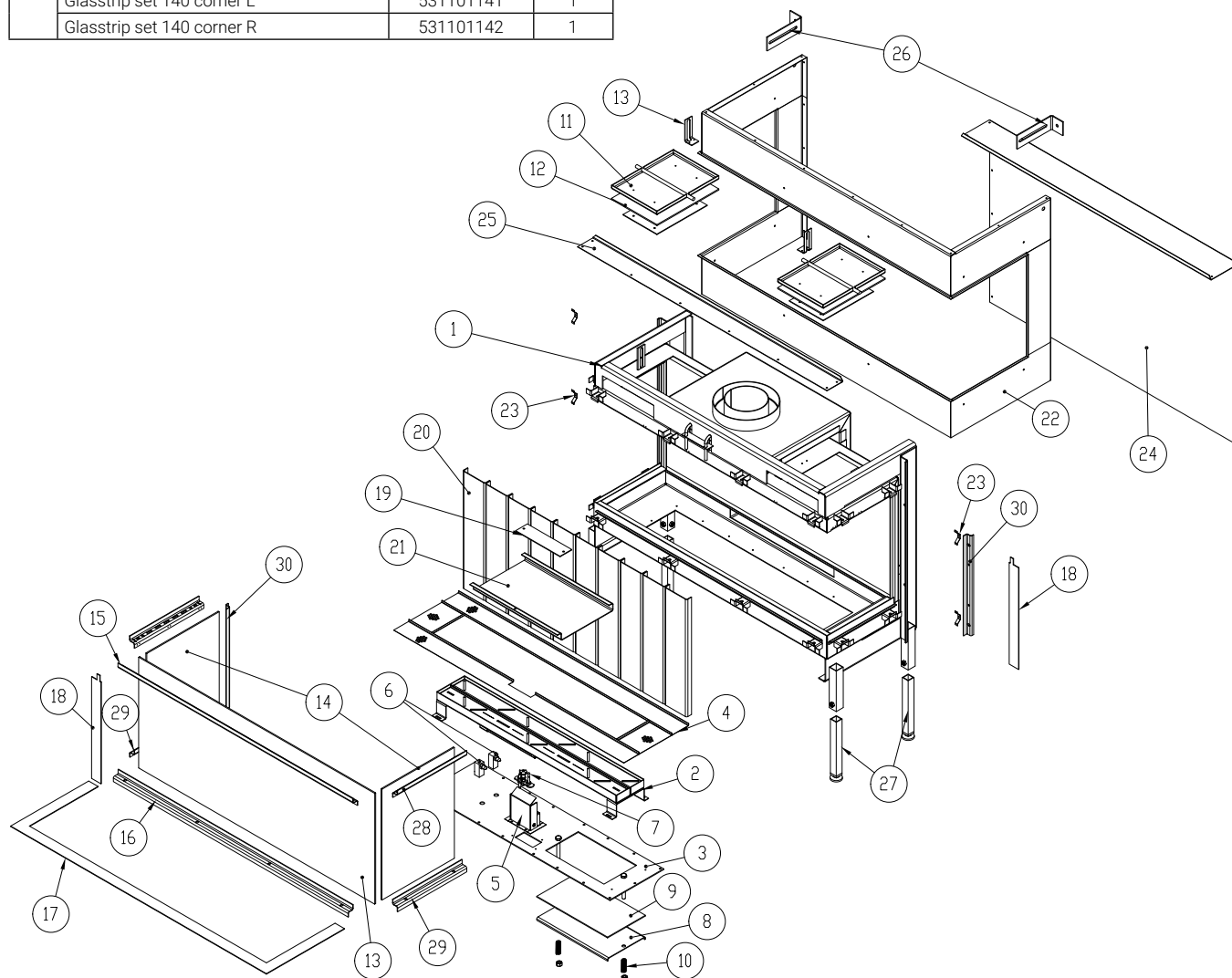

Appendix 6 CONTINUED

No	Description	Artikel Number
1	Burner	x = (on request)
2	Bottomplate burnertray	x
3	Pilotflame protection mesh	x
4	Seal pressure hatch	x
5	Pressure hatch	x
6	Pressure hatch pin	x
7	Pressure hatch spring	x
8	Gascassette Trimline	123010132001
9	10 Gasvalve holder	x
10	Gasvalve bracket old model	x
11	Gastube flex burner 2x 12mm/L 1500mm	601000820
12	Pilot flame gasline 4mm alu	601000747
13	Thermocouple L 1200mm Sit M9 (30sec)	642200912
	Thermocouple L 1500mm Sit M9 (30sec)	642200915
14	Ignition cable L 1200mm 2,Bx0,5-dia 2,3 for 642200884	621002037
	Ignition cable L 1500mm 2,Bx0,5-dia 2,3 for 642200884	621002043
15	Ignition cable sleeve	729900324

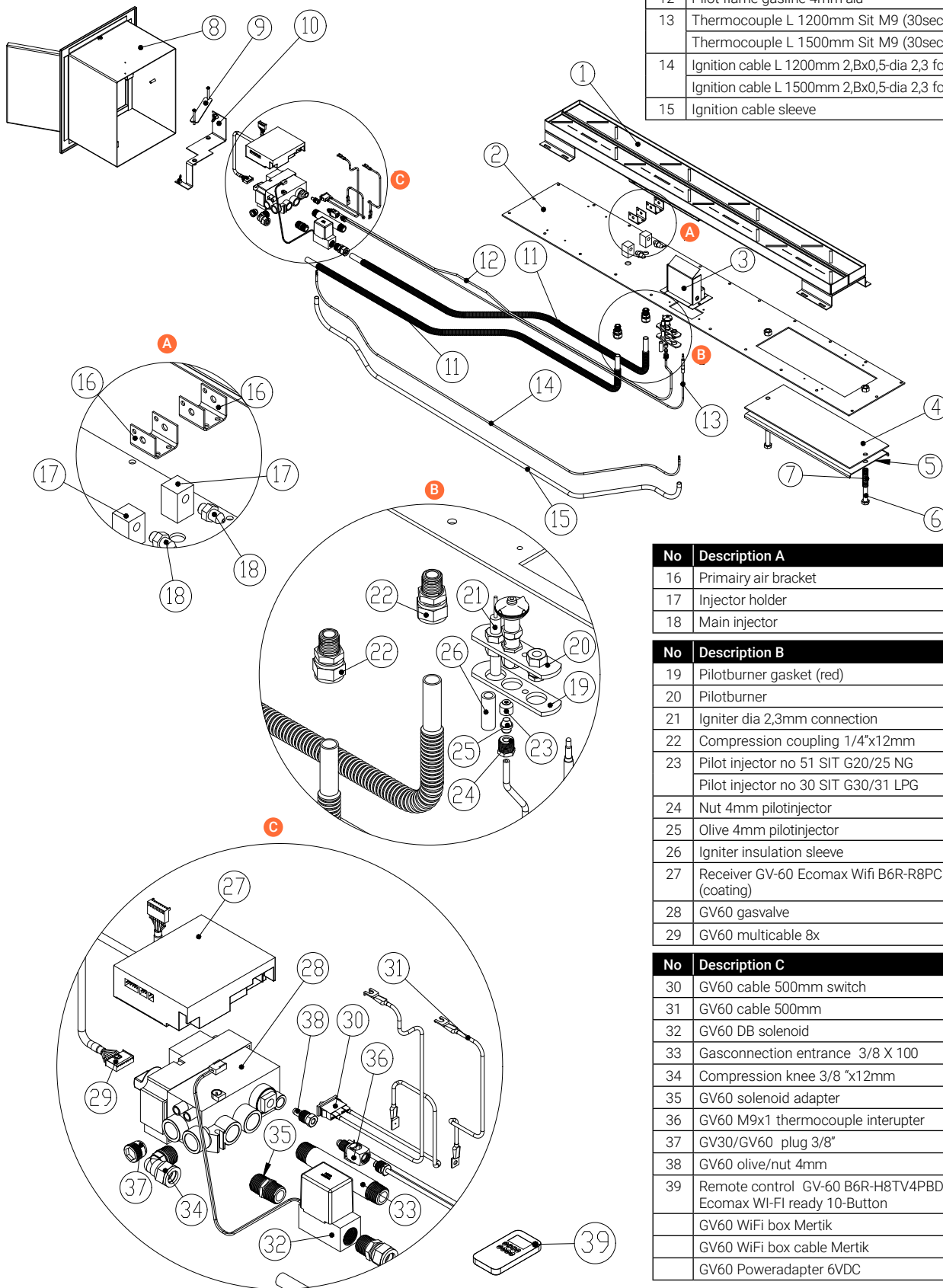



No	Description A	Artikel Number
16	Primary air bracket	see gaskets
17	Injector holder	x
18	Main injector	see gaskets

No	Description B	Artikel Number
19	Pilotburner gasket (red)	721801131
20	Pilotburner	642200432
21	Igniter dia 2,3mm connection	642200884
22	Compression coupling 1/4"x12mm	601200701
23	Pilot injector no 51 SIT G20/25 NG	641800686
	Pilot injector no 30 SIT G30/31 LPG	641800272
24	Nut 4mm pilotinjector	642400229
25	Olive 4mm pilotinjector	642000600
26	Igniter insulation sleeve	729900321
27	Receiver GV-60 Ecomax Wifi B6R-R8PC (coating)	641204005
28	GV60 gasvalve	641200327
29	GV60 multicable 8x	629900027

No	Description C	Artikel Number
30	GV60 cable 500mm switch	621000150
31	GV60 cable 500mm	621000151
32	GV60 DB solenoid	641200329
33	Gasconnection entrance 3/8 X 100	601000750
34	Compression knee 3/8 "x12mm	601200135
35	GV60 solenoid adapter	641200330
36	GV60 M9x1 thermocouple interupter	642200224
37	GV30/GV60 plug 3/8"	601200936
38	GV60 olive/nut 4mm	642400278
39	Remote control GV-60 B6R-H8TV4PBD Ecomax Wi-Fi ready 10-Button	641200996
	GV60 WiFi box Mertik	641200601
	GV60 WiFi box cable Mertik	641200602
	GV60 Poweradapter 6VDC	641200190

V110526

Appendix 7 TYPE PLATE

 www.trimlinefires.com	ART.NO.	115633200001	Type:	C11	C31	C91	AC/DC: 6V DC option																														
	Model:	TRIMLINE 100		PN: 1312DO6772			SN: 2																														
	1156	PANORAMIC		Qn Hi	Pnom	mbar	mbar	m³/h	kg/h																												
<table border="1"> <thead> <tr> <th></th> <th>8,93</th> <th>7,49</th> <th>28,39</th> <th>8,67</th> <th>0,277</th> <th>0,524</th> </tr> </thead> <tbody> <tr> <td>I3+ G30/G31 (28-30)-37mbar BE/CH/CY/CZ/ES/FR/GB/GR/IE/IT/LT/NL/NO/PT/SI/SK/TR</td> <td>8,93</td> <td>7,49</td> <td>28,39</td> <td>8,67</td> <td>0,277</td> <td>0,524</td> </tr> <tr> <td>I3B/P G30 30mbar CY/CZ/DK/EE/FR/GB/HR/HU/IT/LT/PL/RO/SE/SI/SK</td> <td>8,93</td> <td>7,49</td> <td>28,39</td> <td>8,67</td> <td>0,277</td> <td>0,524</td> </tr> <tr> <td>I3B/P G30 50mbar AT/CH/DE/FR/LU/SK</td> <td>8,93</td> <td>7,49</td> <td>28,39</td> <td>8,67</td> <td>0,277</td> <td>0,524</td> </tr> </tbody> </table>											8,93	7,49	28,39	8,67	0,277	0,524	I3+ G30/G31 (28-30)-37mbar BE/CH/CY/CZ/ES/FR/GB/GR/IE/IT/LT/NL/NO/PT/SI/SK/TR	8,93	7,49	28,39	8,67	0,277	0,524	I3B/P G30 30mbar CY/CZ/DK/EE/FR/GB/HR/HU/IT/LT/PL/RO/SE/SI/SK	8,93	7,49	28,39	8,67	0,277	0,524	I3B/P G30 50mbar AT/CH/DE/FR/LU/SK	8,93	7,49	28,39	8,67	0,277	0,524
	8,93	7,49	28,39	8,67	0,277	0,524																															
I3+ G30/G31 (28-30)-37mbar BE/CH/CY/CZ/ES/FR/GB/GR/IE/IT/LT/NL/NO/PT/SI/SK/TR	8,93	7,49	28,39	8,67	0,277	0,524																															
I3B/P G30 30mbar CY/CZ/DK/EE/FR/GB/HR/HU/IT/LT/PL/RO/SE/SI/SK	8,93	7,49	28,39	8,67	0,277	0,524																															
I3B/P G30 50mbar AT/CH/DE/FR/LU/SK	8,93	7,49	28,39	8,67	0,277	0,524																															
<p>NL/BE: Lees de instructies voor installatie en gebruik en plaats volgens de geldende regelgeving in een goed geventileerde ruimte.</p> <p>BE/DE: Lesen Sie die Anleitung sorgfältig durch und stellen Sie das Gerät, nach geltenden Ortsgebrauch der Anord-nungen entsprechend ,auf in einem gut belüfteten Raum.</p> <p>NO: Les instruksjonene før produktet innstalleres og brukes, og plasser innsatsen i et godt ventilert rom i henhold til gjeldende plasseringskrav.</p> <p>GB: Read instructions before installation and use and place the appliance in accordance with the rules in force in a well ventilated room.</p> <p>IT: Legga le istruzioni prima di installazione e di uso e disponga l'apparecchio in conformità con le regole in il vigore in una stanza bene arieggiata.</p> <p>DK: Læs vejledningen inden installation og brug og anbring apparatet i overensstemmelse med gældende regler i et godt ventileret rum</p> <p>ES: Lea las instrucciones para la instalación y el uso del producto Instale el producto en un espacio con buena ventilación, siguiendo las normas vigentes</p> <p>FR/BE: Lire les instructions avant l'installation. Utiliser et placer l'appareil en respectant les règles en vigueur dans une pièce suffisamment ventilée.</p>																																					
									 1312/ 2025																												
							thermoCet Int.B.V. Nederland																														

 www.trimlinefires.com	ART.NO.	114533200001	Type:	C11	C31	C91	AC/DC: 6V DC option																														
	Model:	TRIMLINE 120		PN: 1312DO6772			SN: 2																														
	1145	PANORAMIC		Qn Hi	Pnom	mbar	mbar	m³/h	kg/h																												
<table border="1"> <thead> <tr> <th></th> <th>12,80</th> <th>9,60</th> <th>27,03</th> <th>5,87</th> <th>0,397</th> <th>0,75</th> </tr> </thead> <tbody> <tr> <td>I3+ G30/G31 (28-30)-37mbar BE/CH/CY/CZ/ES/FR/BB/GR/IE/IT/LT//PT/SI//TR</td> <td>12,80</td> <td>9,60</td> <td>27,03</td> <td>5,87</td> <td>0,397</td> <td>0,75</td> </tr> <tr> <td>I3B/P G30 30mbar CY/CZ/DK/EE//HR/HU/IT/LT/PL/RO/SE/SI/SK</td> <td>12,80</td> <td>9,60</td> <td>27,03</td> <td>5,87</td> <td>0,397</td> <td>0,75</td> </tr> <tr> <td>I3B/P G30 50mbar AT/CH/DE//LU/SK</td> <td>12,80</td> <td>9,60</td> <td>27,03</td> <td>5,87</td> <td>0,397</td> <td>0,75</td> </tr> </tbody> </table>											12,80	9,60	27,03	5,87	0,397	0,75	I3+ G30/G31 (28-30)-37mbar BE/CH/CY/CZ/ES/FR/BB/GR/IE/IT/LT//PT/SI//TR	12,80	9,60	27,03	5,87	0,397	0,75	I3B/P G30 30mbar CY/CZ/DK/EE//HR/HU/IT/LT/PL/RO/SE/SI/SK	12,80	9,60	27,03	5,87	0,397	0,75	I3B/P G30 50mbar AT/CH/DE//LU/SK	12,80	9,60	27,03	5,87	0,397	0,75
	12,80	9,60	27,03	5,87	0,397	0,75																															
I3+ G30/G31 (28-30)-37mbar BE/CH/CY/CZ/ES/FR/BB/GR/IE/IT/LT//PT/SI//TR	12,80	9,60	27,03	5,87	0,397	0,75																															
I3B/P G30 30mbar CY/CZ/DK/EE//HR/HU/IT/LT/PL/RO/SE/SI/SK	12,80	9,60	27,03	5,87	0,397	0,75																															
I3B/P G30 50mbar AT/CH/DE//LU/SK	12,80	9,60	27,03	5,87	0,397	0,75																															
<p>NL/BE: Lees de instructies voor installatie en gebruik en plaats volgens de geldende regelgeving in een goed geventileerde ruimte.</p> <p>BE/DE: Lesen Sie die Anleitung sorgfältig durch und stellen Sie das Gerät, nach geltenden Ortsgebrauch der Anord-nungen entsprechend ,auf in einem gut belüfteten Raum.</p> <p>NO: Les instruksjonene før produktet innstalleres og brukes, og plasser innsatsen i et godt ventilert rom i henhold til gjeldende plasseringskrav.</p> <p>GB: Read instructions before installation and use and place the appliance in accordance with the rules in force in a well ventilated room.</p> <p>IT: Legga le istruzioni prima di installazione e di uso e disponga l'apparecchio in conformità con le regole in il vigore in una stanza bene arieggiata.</p> <p>DK: Læs vejledningen inden installation og brug og anbring apparatet i overensstemmelse med gældende regler i et godt ventileret rum</p> <p>ES: Lea las instrucciones para la instalación y el uso del producto Instale el producto en un espacio con buena ventilación, siguiendo las normas vigentes</p> <p>FR/BE: Lire les instructions avant l'installation. Utiliser et placer l'appareil en respectant les règles en vigueur dans une pièce suffisamment ventilée.</p>																																					
									 1312/ 2025																												
							thermoCet Int.B.V. Nederland																														

 www.trimlinefires.com	ART.NO.	114033000001	Type:	C11	C31	C91	AC/DC: 6V DC option																														
	Model:	TRIMLINE 140		PN: 1312DO6772			SN: 3																														
	1140	PANORAMIC		Qn Hi	Pnom	mbar	mbar	m³/h	kg/h																												
<table border="1"> <thead> <tr> <th></th> <th>12,32</th> <th>9,49</th> <th>26,35</th> <th>10,64</th> <th>0,382</th> <th>0,722</th> </tr> </thead> <tbody> <tr> <td>I3+ G30/G31 (28-30)-37mbar BE/CH/CY/CZ/ES/FR/BB/GR/IE/IT/LT//PT/SI//TR</td> <td>12,32</td> <td>9,49</td> <td>26,35</td> <td>10,64</td> <td>0,382</td> <td>0,722</td> </tr> <tr> <td>I3B/P G30 30mbar CY/CZ/DK/EE//HR/HU/IT/LT/PL/RO/SE/SI/SK</td> <td>12,32</td> <td>9,49</td> <td>26,35</td> <td>10,64</td> <td>0,382</td> <td>0,722</td> </tr> <tr> <td>I3B/P G30 50mbar AT/CH/DE//LU/SK</td> <td>12,32</td> <td>9,49</td> <td>26,35</td> <td>10,64</td> <td>0,382</td> <td>0,722</td> </tr> </tbody> </table>											12,32	9,49	26,35	10,64	0,382	0,722	I3+ G30/G31 (28-30)-37mbar BE/CH/CY/CZ/ES/FR/BB/GR/IE/IT/LT//PT/SI//TR	12,32	9,49	26,35	10,64	0,382	0,722	I3B/P G30 30mbar CY/CZ/DK/EE//HR/HU/IT/LT/PL/RO/SE/SI/SK	12,32	9,49	26,35	10,64	0,382	0,722	I3B/P G30 50mbar AT/CH/DE//LU/SK	12,32	9,49	26,35	10,64	0,382	0,722
	12,32	9,49	26,35	10,64	0,382	0,722																															
I3+ G30/G31 (28-30)-37mbar BE/CH/CY/CZ/ES/FR/BB/GR/IE/IT/LT//PT/SI//TR	12,32	9,49	26,35	10,64	0,382	0,722																															
I3B/P G30 30mbar CY/CZ/DK/EE//HR/HU/IT/LT/PL/RO/SE/SI/SK	12,32	9,49	26,35	10,64	0,382	0,722																															
I3B/P G30 50mbar AT/CH/DE//LU/SK	12,32	9,49	26,35	10,64	0,382	0,722																															
<p>NL/BE: Lees de instructies voor installatie en gebruik en plaats volgens de geldende regelgeving in een goed geventileerde ruimte.</p> <p>BE/DE: Lesen Sie die Anleitung sorgfältig durch und stellen Sie das Gerät, nach geltenden Ortsgebrauch der Anord-nungen entsprechend ,auf in einem gut belüfteten Raum.</p> <p>NO: Les instruksjonene før produktet innstalleres og brukes, og plasser innsatsen i et godt ventilert rom i henhold til gjeldende plasseringskrav.</p> <p>GB: Read instructions before installation and use and place the appliance in accordance with the rules in force in a well ventilated room.</p> <p>IT: Legga le istruzioni prima di installazione e di uso e disponga l'apparecchio in conformità con le regole in il vigore in una stanza bene arieggiata.</p> <p>DK: Læs vejledningen inden installation og brug og anbring apparatet i overensstemmelse med gældende regler i et godt ventileret rum</p> <p>ES: Lea las instrucciones para la instalación y el uso del producto Instale el producto en un espacio con buena ventilación, siguiendo las normas vigentes</p> <p>FR/BE: Lire les instructions avant l'installation. Utiliser et placer l'appareil en respectant les règles en vigueur dans une pièce suffisamment ventilée.</p>																																					
									 1312/ 2025																												
							thermoCet Int.B.V. Nederland																														



Appendix 7 CONTINUED

 www.trimlinefires.com	ART.NO.	11561300001	Type:	C11	C31	C91	AC/DC: 6V DC option		
	Model:	TRIMLINE 100		PN: 1312DO6772			SN: 2		
	1156	PANORAMIC		Hi	Pb-high	Pb-low			
		<i>12EK G25.3-25mbar NL</i>		Qn Hi	Pnom	mbar	mbar	m ³ /h	kg/h
		<i>12H G20-20mbar AT/CH/CY/CZ/DK/EE/CH/ES/FR/GB/GR/HR/HU/IE/IT/LT/LV/NL/NO/PT/RO/SE/SI/SK/TR</i>		10,55	8,02	17,37	4,60	1,270	
		<i>12E G20-20mbar DE/NL/PL/RO</i>		11,25	8,66	13,92	3,71	1,190	
		<i>12E+ G20±G25 20±25mbar BE/FR</i>		11,25	8,66	13,92	3,71	1,19	
		<i>12ELL G20/G25-20mbar DE</i>		11,3±10,5	8,66	13,92±17,37	3,71±4,6	1,19	
				9,09	6,66	14,10	3,60	1,119	

NL/BE: Lees de instructies voor installatie en gebruik en plaats volgens de geldende regelgeving in een goed geventileerde ruimte.
BE/DE: Lesen Sie die Anleitung sorgfältig durch und stellen Sie das Gerät, nach geltenden Ortsgebrauch der Anord-nungen entsprechend ,auf in einem gut belüfteten Raum.
NO: Les instruksjonene før produktet innstalleres og brukes, og plasser innsatsen i et godt ventilert rom i henhold til gjeldende plasseringskrav.
GB: Read instructions before installation and use and place the appliance in accordance with the rules in force in a well ventilated room.
IT: Legga le istruzioni prima di installazione e di uso e disponga l'apparecchio in conformità con le regole in il vigore in una stanza bene arieggiata.
DK: Læs vejledningen inden installation og brug og anbring apparatet i overensstemmelse med gældende regler i et godt ventileret rum
ES: Lea las instrucciones para la instalación y el uso del producto Instale el producto en un espacio con buena ventilación, siguiendo las normas vigentes
FR/BE: Lire les instructions avant l'installation. Utiliser et placer l'appareil en respectant les règles en vigueur dans une pièce suffisamment ventilée.

thermoCet Int.B.V. Nederland

 www.trimlinefires.com	ART.NO.	11451300001	Type:	C11	C31	C91	AC/DC: 6V DC option		
	Model:	TRIMLINE 120		PN: 1312DO6772			SN: 2		
	1145	PANORAMIC		Hi	Pb-high	Pb-low			
		<i>12EK G25.3-25mbar NL</i>		Qn Hi	Pnom	mbar	mbar	m ³ /h	kg/h
		<i>12H G20-20mbar AT/CH/CZ/DK/EE/CH/ES/FR/GB/GR/HR/HU/IE/IT/LT/LV/NO/PT/RO/SE/SI/SK/TR</i>		12,11	9,75	16,67	7,76	1,457	
		<i>12E G20-20mbar DE//PL/RO</i>		12,75	10,21	13,41	6,35	1,349	
		<i>12E+ G20±G25 20±25mbar BE/FR</i>		12,75	10,21	13,41	6,35	1,349	
		<i>12ELL G20/G25-20mbar DE</i>		12,8±12,1	10,21	13,41±16,67	6,35±7,76	1,349	
				10,38	8,20	13,29	6,08	1,278	

NL/BE: Lees de instructies voor installatie en gebruik en plaats volgens de geldende regelgeving in een goed geventileerde ruimte.
BE/DE: Lesen Sie die Anleitung sorgfältig durch und stellen Sie das Gerät, nach geltenden Ortsgebrauch der Anord-nungen entsprechend ,auf in einem gut belüfteten Raum.
NO: Les instruksjonene før produktet innstalleres og brukes, og plasser innsatsen i et godt ventilert rom i henhold til gjeldende plasseringskrav.
GB: Read instructions before installation and use and place the appliance in accordance with the rules in force in a well ventilated room.
IT: Legga le istruzioni prima di installazione e di uso e disponga l'apparecchio in conformità con le regole in il vigore in una stanza bene arieggiata.
DK: Læs vejledningen inden installation og brug og anbring apparatet i overensstemmelse med gældende regler i et godt ventileret rum
ES: Lea las instrucciones para la instalación y el uso del producto Instale el producto en un espacio con buena ventilación, siguiendo las normas vigentes
FR/BE: Lire les instructions avant l'installation. Utiliser et placer l'appareil en respectant les règles en vigueur dans une pièce suffisamment ventilée.

thermoCet Int.B.V. Nederland

 www.trimlinefires.com	ART.NO.	11401300001	Type:	C11	C31	C91	AC/DC: 6V DC option		
	Model:	TRIMLINE 140		PN: 1312DO6772			SN: 3		
	1140	PANORAMIC		Hi	Pb-high	Pb-low			
		<i>12H G20-20mbar AT/CH/CZ/DK/EE/CH/ES/FR/GB/GR/HR/HU/IE/IT/LT/LV/NO/PT/RO/SE/SI/SK/TR</i>		Qn Hi	Pnom	mbar	mbar	m ³ /h	kg/h
		<i>12E G20-20mbar DE//PL/RO</i>		14,27	11,43	16,29	4,30	1,510	
		<i>12E+ G20±G25 20±25mbar BE/FR</i>		14,27	11,43	16,29	4,30	1,51	
		<i>12ELL G20/G25-20mbar DE</i>		14,3±13,7	11,43	16,29±20,3	4,3±5,21	1,51	
				11,41	8,91	16,83	4,18	1,404	

NL/BE: Lees de instructies voor installatie en gebruik en plaats volgens de geldende regelgeving in een goed geventileerde ruimte.
BE/DE: Lesen Sie die Anleitung sorgfältig durch und stellen Sie das Gerät, nach geltenden Ortsgebrauch der Anord-nungen entsprechend ,auf in einem gut belüfteten Raum.
NO: Les instruksjonene før produktet innstalleres og brukes, og plasser innsatsen i et godt ventilert rom i henhold til gjeldende plasseringskrav.
GB: Read instructions before installation and use and place the appliance in accordance with the rules in force in a well ventilated room.
IT: Legga le istruzioni prima di installazione e di uso e disponga l'apparecchio in conformità con le regole in il vigore in una stanza bene arieggiata.
DK: Læs vejledningen inden installation og brug og anbring apparatet i overensstemmelse med gældende regler i et godt ventileret rum
ES: Lea las instrucciones para la instalación y el uso del producto Instale el producto en un espacio con buena ventilación, siguiendo las normas vigentes
FR/BE: Lire les instructions avant l'installation. Utiliser et placer l'appareil en respectant les règles en vigueur dans une pièce suffisamment ventilée.

thermoCet Int.B.V. Nederland

Appendix 8 DECLARATION OF CONFORMITY

DECLARATION OF CONFORMITY



Appliance or equipment/model of appliance or equipment (product, type, batch or serial number)	Model: Trimline 100 Panoramic/Corner (1156-1157-1158) Trimline 120 Panoramic/Corner (1145-1146-1147) Trimline 140 Panoramic/Corner (1140-1141-1142) Type: C11 C31 C91 Independent closed-fronted gas-fired SN Type plate on appliance for Serialnumber	CE
Name and address of the manufacturer and, if applicable, of his authorised representative	Thermocet International B.V. - Laagerfseweg 27, 3931 PC, Woudenberg www.trimlinefires.com	
This declaration of conformity is issued under the sole responsibility of the manufacturer.		
References of the relevant harmonised standards applied or other technical specifications against which conformity is declared		
NEN-EN613:2022		
In conformity with the applicable Union harmonisation legislation	(EU) 2016/426	
In the case of equipment, instructions on how to incorporate the equipment into an appliance or assemble it to form an appliance, in order to contribute to compliance with the essential requirements for finished appliances.	read Instruction manual	
Notified body	CERTIGAZ SAS 1 rue du Général Leclerc – 92 800 Puteaux Standard : +33 (0)1 80 21 07 179	
Notified body/Certificate number	PIN/Cert 1312DO6772	

Organisme Notifié N° 1312
Notified Body 1312

MODULE B
EXAMEN UE DE TYPE – TYPE DE PRODUCTION | EU TYPE EXAMINATION – PRODUCTION
Règlement (UE) 2016/426 « Appareils à gaz » Paragraphe 1 – Annexe III
Regulation (EU) 2016/426 « Gas appliances » Paragraph 1 – Annex III
Certificat / Certificate n° : 1312DO6772

CERTIGAZ, après examen et vérifications, certifie que l'appareil :
CERTIGAZ, after examination and verifications, certifies that the appliance:

- Fabricant / Manufacturer : THERMOCET INTERNATIONAL B.V., Laagerfseweg 27 - 3931 PC, Woudenberg - THE NETHERLANDS
- Fabriqué par / Manufactured by : TTI Thermo Technology International d.o.o., KRUMAVSKA BB, Zavidovič - BOSNIA AND HERZEGOVINA
- Marque(s) commerciale(s) / Trade mark and model(s) : THERMOCET
 - > Trimline 100 P DB (1156) > Trimline 140 P DB (1140)
 - > Trimline 100 CL DB (1157) > Trimline 140 CL DB (1141)
 - > Trimline 100 CR DB (1158) > Trimline 140 CR DB (1142)
 - > Trimline 120 P DB (1145)
 - > Trimline 120 CL DB (1146)
 - > Trimline 120 CR DB (1147)
- Genre de l'appareil / Kind of the appliance : APPAREIL DE CHAUFFAGE AU GAZ A CONVECTION INDEPENDANT / INDEPENDENT GAS-FIRED CONVECTION HEATER / Système évacuation / Flue system: C11-C31-C91
- Désignation du type / Type designation : Trimline 100-120-140 Panoramic / Corner

Pays de destination / Destination countries	Pression (mbar) / Pressure (mbar)	Catégories / Categories
DE, PL, RO	20	DH
AT, CH, CZ, DK, EE, ES, FI, GB, GR, HR, IE, IT, LT, LU, LV, NO, PT, RO, SE, SI, SK, TR	20/25	DH+
BE, FR	25	D2K
NL	20	D2LL
AT, CH, CZ, DK, EE, ES, FI, GB, GR, HR, HU, IT, LT, NL, NO, PL, RO, SE, SI, TR	30/50	D3P
BE, CH, CY, CZ, ES, FR, GB, GR, IE, IT, LT, PT, SI, TR	20-30 / 30/37	E3+

Est conforme aux exigences essentielles du Règlement (UE) 2016/426 « Appareils à gaz », / Is in conformity with essential requirements of « Gas appliances » (EU) 2016/426 Regulation.

Toute reproduction de ce certificat doit être dans son intégralité. / Reproduction of this certificate must be in full.
Ce certificat est valide 10 ans à partir de la date de signature. Il annule tout certificat antérieur. / Validity date 10 years since signature day. It cancels any previous certificate.

CERTIFICATION DE PRODUITS ET SERVICES

Puteaux, le 21 juillet 2023

Le Directeur Général

Claude C. Amon

CERTIGAZ SAS - 1 rue du Général Leclerc - CS 60204 - F 92047 Paris la Défense Cedex - TB - +33 (0)1 80 21 07 43
 info@certigaz.fr • www.certigaz.fr • Siret: 441 277 934 00040 RCS Nanterre • Capital social: 440 000 euros

Signed on behalf of the manufacturer by:

 Tjarco Jilesen, CEO
 Juli-2023, Woudenberg
www.ihs-group.com

Product sheet EU 2015/1186 **Trimline 100 (1156-1157-1158)**

The information on the product data sheet of the local space heater appliance is provided in the order listed below and included in the product brochure or other written information supplied with the product.

Manufacturer	thermoCet International B.V. Nederland							
Indication type	Trimline 100 Panoramic/Corner (1156-1157-1158)							
	Category	I2EK	I2H	I2E	I2E+	I2ELL	I3+	I3B/P
	Gas type	G25.3	G20	G20	G20⇄G25	G20/G25	G30/G31	G30
Energy efficiency class		D	D	D	D	E		
Direct heat output	Pnom	%	8,02	8,66	8,66	8,66	6,66	
Indirect heat output	not applicable							
Energy Efficiency Index (EEI)	Index		73	74	74	74	71	
For nominal heat output	ηth.nom	%	76,00	77,00	77,00	77,00	73,24	
For minimal heat output	ηth.min	%	53,34	54,72	54,72	54,72	50,25	
Any specific precautions to be taken when assembling, installing or maintaining the space heater.	 Indicator read manual	Read instructions before installation and use and place the appliance in accordance with the local building rules in force in a well ventilated room. Product only to be installed and maintained by a certified installer.						

thermoCet International B.V.
Laagerfseweg 27
3931 PC Woudenberg
Netherlands

Product sheet EU 2015/1186

Trimline 100 (1156-1157-1158)

The information on the product data sheet of the local space heater appliance is provided in the order listed below and included in the product brochure or other written information supplied with the product.

Manufacturer	thermoCet International B.V. Nederland							
Indication type	Trimline 100 Panoramic/Corner (1156-1157-1158)							
	Category	I2EK	I2H	I2E	I2E+	I2ELL	I3+	I3B/P
	Gas type	G25.3	G20	G20	G20⇆G25	G20/G25	G30/G31	G30
Energy efficiency class							C	C
Direct heat output	Pnom	%					7,49	7,49
Indirect heat output	not applicable							
Energy Efficiency Index (EEI)	Index						81	81
For nominal heat output	ηth.nom	%					83,87	83,87
For minimal heat output	ηth.min	%					72,28	72,28
Any specific precautions to be taken when assembling, installing or maintaining the space heater.	 Indicator read manual	Read instructions before installation and use and place the appliance in accordance with the local building rules in force in a well ventilated room. Product only to be installed and maintained by a certified installer.						
thermoCet International B.V. Laagerfseweg 27 3931 PC Woudenberg Netherlands								

Product sheet EU 2015/1186

Trimline 120 Panoramic/Corner (1145-1146-1147)

The information on the product data sheet of the local space heater appliance is provided in the order listed below and included in the product brochure or other written information supplied with the product.

Manufacturer	thermoCet International B.V. Nederland							
Indication type	Trimline 120 Panoramic/Corner (1145-1146-1147)							
	Category	I2EK	I2H	I2E	I2E+	I2ELL	I3+	I3B/P
	Gas type	G25.3	G20	G20	G20⇄G25	G20/G25	G30/G31	G30
Energy efficiency class		C	C	C	C	D		
Direct heat output	Pnom	%	9,75	10,21	10,21	10,21	8,20	
Indirect heat output	not applicable							
Energy Efficiency Index (EEI)	Index		78	77	77	77	76	
For nominal heat output	ηth.nom	%	80,52	80,08	80,08	80,08	79,01	
For minimal heat output	ηth.min	%	68,66	69,00	69,00	69,00	66,23	
Any specific precautions to be taken when assembling, installing or maintaining the space heater.	 Indicator read manual	Read instructions before installation and use and place the appliance in accordance with the local building rules in force in a well ventilated room. Product only to be installed and maintained by a certified installer.						
								thermoCet International B.V. Laagerfseweg 27 3931 PC Woudenberg Netherlands

Product sheet EU 2015/1186

Trimline 120 Panoramic/Corner (1145-1146-1147)

The information on the product data sheet of the local space heater appliance is provided in the order listed below and included in the product brochure or other written information supplied with the product.

Manufacturer	thermoCet International B.V. Nederland							
Indication type	Trimline 120 Panoramic/Corner (1145-1146-1147)							
	Category	I2EK	I2H	I2E	I2E+	I2ELL	I3+	I3B/P
	Gas type	G25.3	G20	G20	G20⇆G25	G20/G25	G30/G31	G30
Energy efficiency class							D	D
Direct heat output	Pnom	%					9,60	9,60
Indirect heat output	not applicable							
Energy Efficiency Index (EEI)	Index						72	72
For nominal heat output	$\eta_{th.nom}$	%					75,02	75,02
For minimal heat output	$\eta_{th.min}$	%					63,98	63,98
Any specific precautions to be taken when assembling, installing or maintaining the space heater.	 Indicator read manual	Read instructions before installation and use and place the appliance in accordance with the local building rules in force in a well ventilated room. Product only to be installed and maintained by a certified installer.						
thermoCet International B.V. Laagerfseweg 27 3931 PC Woudenberg Netherlands								

Product sheet EU 2015/1186

Trimline 140 (1140-1141-1142)

The information on the product data sheet of the local space heater appliance is provided in the order listed below and included in the product brochure or other written information supplied with the product.

Manufacturer	thermoCet International B.V. Nederland							
Indication type	Trimline 140 Panoramic/Corner (1140-1141-1142)							
	Category	I2EK	I2H	I2E	I2E+	I2ELL	I3+	I3B/P
	Gas type	G25.3	G20	G20	G20⇆G25	G20/G25	G30/G31	G30
Energy efficiency class			C	C	C	D		
Direct heat output	Pnom	%		11,43	11,43	11,43	8,91	
Indirect heat output	not applicable							
Energy Efficiency Index (EEI)	Index			77	77	77	75	
For nominal heat output	ηth.nom	%		80,07	80,07	80,07	78,11	
For minimal heat output	ηth.min	%		68,51	68,51	68,51	66,87	
Any specific precautions to be taken when assembling, installing or maintaining the space heater.	 Indicator read manual	Read instructions before installation and use and place the appliance in accordance with the local building rules in force in a well ventilated room. Product only to be installed and maintained by a certified installer.						
								thermoCet International B.V. Laagerfseweg 27 3931 PC Woudenberg Netherlands

Product sheet EU 2015/1186

Trimline 140 (1140-1141-1142)

The information on the product data sheet of the local space heater appliance is provided in the order listed below and included in the product brochure or other written information supplied with the product.

Manufacturer	thermoCet International B.V. Nederland							
Indication type	Trimline 140 Panoramic/Corner (1140-1141-1142)							
	Category	I2EK	I2H	I2E	I2E+	I2ELL	I3+	I3B/P
	Gas type	G25.3	G20	G20	G20⇄G25	G20/G25	G30/G31	G30
Energy efficiency class		D						
Direct heat output	Pnom	%	10,67					
Indirect heat output	not applicable							
Energy Efficiency Index (EEI)	Index		75					
For nominal heat output	ηth.nom	%	77,68					
For minimal heat output	ηth.min	%	64,63					
Any specific precautions to be taken when assembling, installing or maintaining the space heater.	 Indicator read manual	Read instructions before installation and use and place the appliance in accordance with the local building rules in force in a well ventilated room. Product only to be installed and maintained by a certified installer.						
thermoCet International B.V. Laagerfseweg 27 3931 PC Woudenberg Netherlands								

Product sheet EU 2015/1186 **Trimline 140 (1140-1141-1142)**

The information on the product data sheet of the local space heater appliance is provided in the order listed below and included in the product brochure or other written information supplied with the product.

Manufacturer	thermoCet International B.V. Nederland							
Indication type	Trimline 140 Panoramic/Corner (1140-1141-1142)							
	Category	I2EK	I2H	I2E	I2E+	I2ELL	I3+	I3B/P
	Gas type	G25.3	G20	G20	G20⇆G25	G20/G25	G30/G31	G30
Energy efficiency class							D	D
Direct heat output	Pnom	%					9,49	9,49
Indirect heat output	not applicable							
Energy Efficiency Index (EEI)	Index						74	74
For nominal heat output	ηth.nom	%					77,04	77,04
For minimal heat output	ηth.min	%					67,12	67,12
Any specific precautions to be taken when assembling, installing or maintaining the space heater.	 Indicator read manual	Read instructions before installation and use and place the appliance in accordance with the local building rules in force in a well ventilated room. Product only to be installed and maintained by a certified installer.						

thermoCet International B.V.
Laagerfseweg 27
3931 PC Woudenberg
Netherlands

ENERGY
енергия · ενεργεια

Y IJA
IE IA

Trimline 100 1156-1157-1158 G20

trimline fires

A++ A+ A B C D E F G

D

8,66 kW

ENERGIA · ЕНЕРГИЯ · ENERGIEIA · ENERGIA · ENERGY · ENERGIE · ENERGI

2015/1186

ENERGY
енергия · ενεργεια

Y IJA
IE IA

Trimline 100 1156-1157-1158 G25.3

trimline fires

A++ A+ A B C D E F G

D

8,02 kW

ENERGIA · ЕНЕРГИЯ · ENERGIEIA · ENERGIA · ENERGY · ENERGIE · ENERGI

2015/1186

ENERG
енергия · ΕΝΕΡΓΕΙΑ

Trimline 100 1156-1157-1158 G30/G31

trimline fires

C

A++ A+ A B C D E F G

7,49 kW

ENERGIA · ЕНЕРГИЯ · ENERGIEIA · ENERGIA · ENERGY · ENERGIE · ENERGI

2015/1186

ENERG
енергия · ΕΝΕΡΓΕΙΑ

Trimline 100 1156-1157-1158 G20G25

trimline fires

E

A++ A+ A B C D E F G

6,66 kW

ENERGIA · ЕНЕРГИЯ · ENERGIEIA · ENERGIA · ENERGY · ENERGIE · ENERGI

2015/1186

ENERGIA · ЕНЕРГИЈА · ENERGIE · ENERGIJA · ENERGY · ENERGIE · ENERGI

Trimline 120 1145-1146-1147 G20G25

trimline fires

A++ A+ A B C D E F G

D

8,20 kW

ENERGIA · ЕНЕРГИЈА · ENERGIE · ENERGIJA · ENERGY · ENERGIE · ENERGI

2015/1186

ENERGIA · ЕНЕРГИЈА · ENERGIE · ENERGIJA · ENERGY · ENERGIE · ENERGI

Trimline 120 1145-1146-1147 G20

trimline fires

A++ A+ A B C D E F G

C

10,21 kW

ENERGIA · ЕНЕРГИЈА · ENERGIE · ENERGIJA · ENERGY · ENERGIE · ENERGI



2015/1186



ENERG
енергия · ΕΝΕΡΓΕΙΑ

Y IJA
IE IA

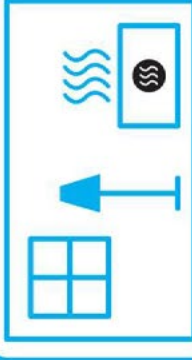
Trimline 120 1145-1146-1147 G30/G31



9,60
kW



ENERGIA · ЕНЕРГИЯ · ENERGIEIA · ENERGIJA · ENERGY · ENERGIE · ENERGI

2015/1186

ENERG
енергия · ΕΝΕΡΓΕΙΑ

Y IJA
IE IA

Trimline 120 1145-1146-1147 G25.3





9,75
kW

ENERGIA · ЕНЕРГИЯ · ENERGIEIA · ENERGIJA · ENERGY · ENERGIE · ENERGI

2015/1186

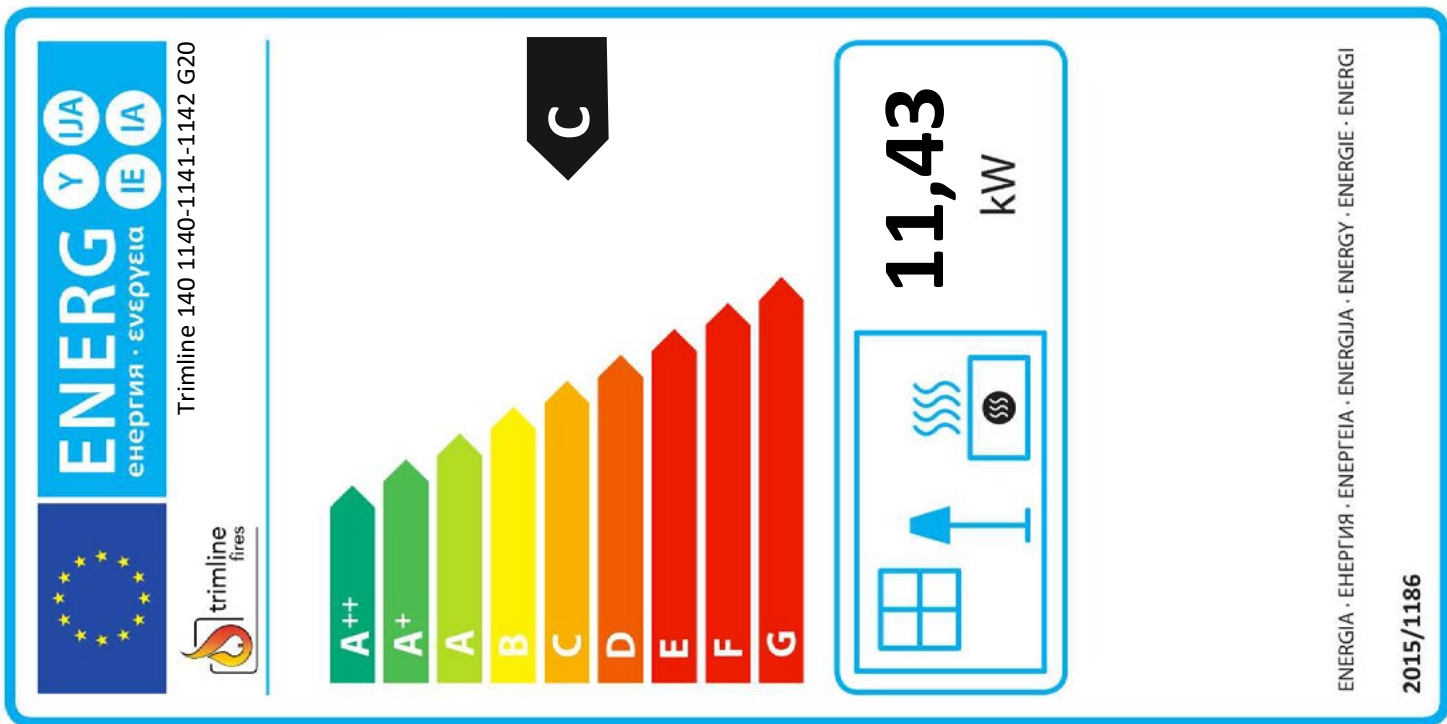
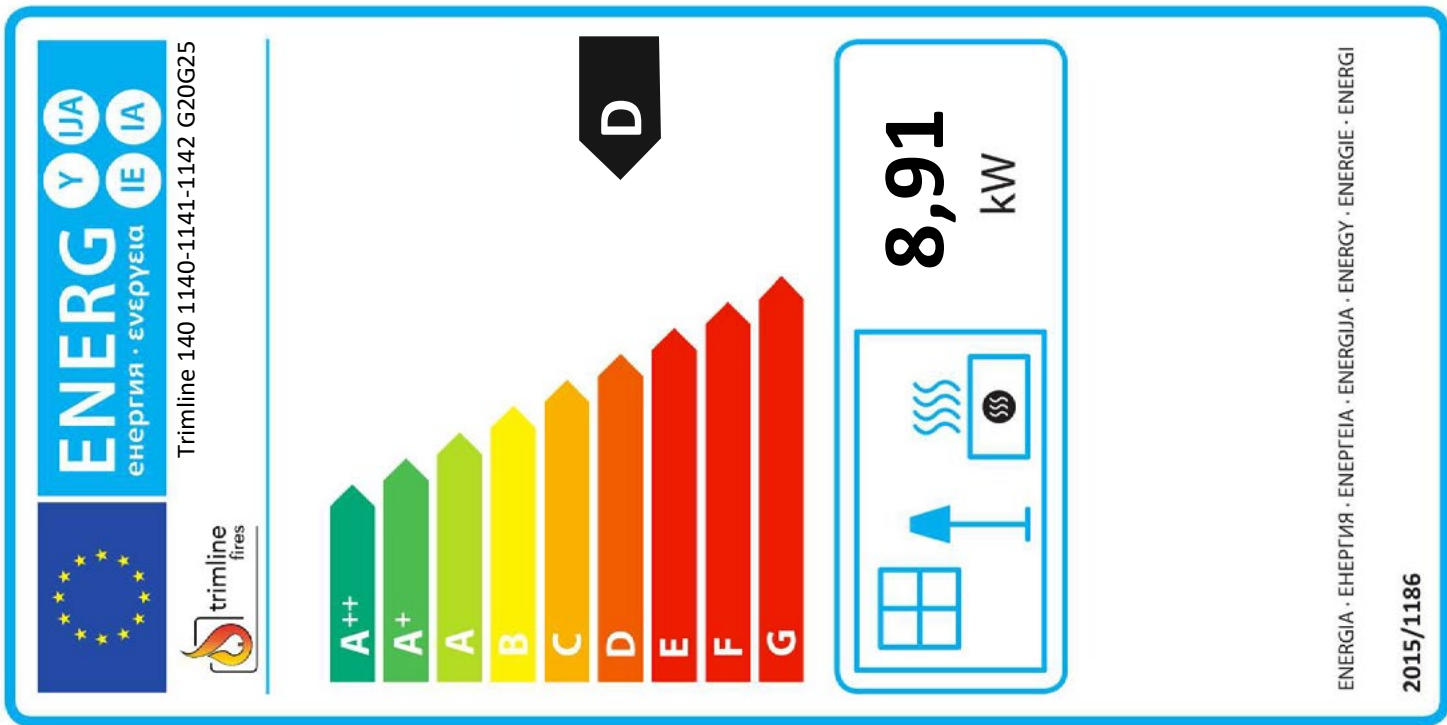





Trimline 140 1140-1141-1142 G30/G31

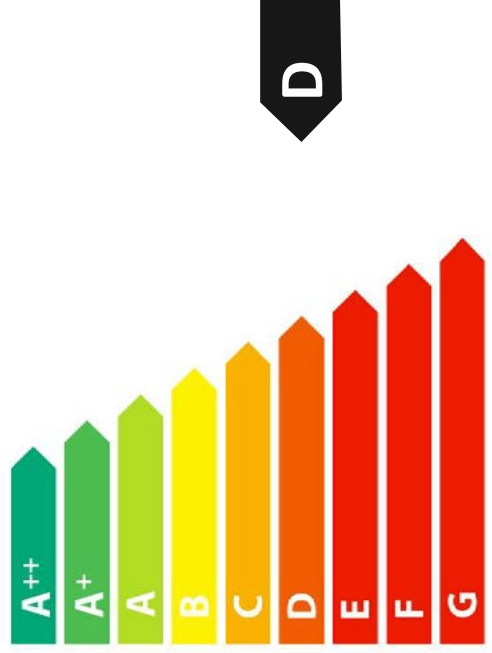

D

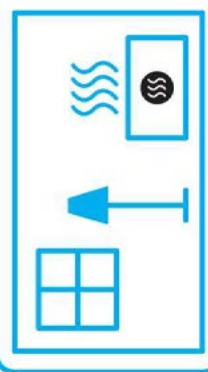

9,49
kW

ENERGIA · ЕНЕРГИЯ · ENERGIEIA · ENERGIA · ENERGY · ENERGIE · ENERGI

2015/1186



Trimline 140 1140-1141-1142 G25.3



D



10,67
kW

ENERGIA · ЕНЕРГИЯ · ENERGIEIA · ENERGIA · ENERGY · ENERGIE · ENERGI

2015/1186

